

ZEXEL - TEST VALUES
Injection pumps

BOSCH No. : 9 400 610 151 1/3
ZEXEL No. : 101472-0080
Date : 30.09.1991 [1]
Company : ISUZU
Engine : C240 / 8-97027-705-0

IP-Type number : 101047-9010 / PES4A
Governor type number : 105419-0620 / EP/RSV

TEST PREREQUISITES

Test oil : ISO-4113
Test oil inlet temperature °C : 40.00...45.00
Inlet pressure bar : 1.6
Test nozzle holder combination : 1 688 901 013
Opening pressure bar : 175
Test pressure line
Inner x Outer Dia - Length mm : 2.00 x 6.00 x 600

PORT CLOSING

Prestroke mm : 2.25 ± 0.05
Rod position mm : -
Port closing mark Cyl. No. : -
Cam sequence : 1 - 3 - 4 - 2

Port closing mark Cyl. No. : -
Port closing difference °NW : 0-90-180-270

Tolerance +- °C: 0.50 (0.75)

A1

ZEXEL - Test values
Injection pumps



Injection Quantity :

Adjusting Point	Rod Pos. (mm)	Speed (rpm)	Injection Q'ty (cc/1000 str.)	Difference (%)	Fixed	Remarks
A	9.6	750	25.9 - 27.9	± 2.5	Rack	Basic
	approx. 8.9	350	6.9 - 9.1	± 14	Rack	
A	9.6	750	25.9 - 27.9	-	Lever	Basic
B	10.0	725	32.2 - 35.2	-	Lever	
C	(13.2) ± 0.1	100	-	-	Lever	Control rack limit
D	7.7	N ₁	-	-	Lever	
E	9.6	900	-	-	Lever	
F	7.7	N ₂	-	-	Lever	

Timing Advance Specification :

Speed (rpm)							
Advance Angle (deg)							

	Pump Speed (rpm)	Rack Position (mm)	Remarks
Full-load Adjustment (Temporary)	600 - 700 750	10.0 10.0	<ul style="list-style-type: none"> • Adjust using screw (1) • Adjust using screw (2)
Torque Control Spring Adjustment	600 570 - 630 610 - 690	10.3 10.3 10.0	<ul style="list-style-type: none"> • Adjust using spring capsule (4) • Confirm • Confirm the torque control stroke 0.3 mm
Idling Adjustment	780 - 350	7.7 5.5 - 6.7 8.6	<ul style="list-style-type: none"> • Confirm • Adjust using spring capsule (5) • Adjusting using control lever
Maximum-speed Adjustment	745 - 755	9.6	<ul style="list-style-type: none"> • Adjust using screw (2)
Control Lever Angle Measurement	<ul style="list-style-type: none"> • Measure the control lever angle at the "idling" and "full" positions. • When the control lever is depressed toward the "full" position, replace the shifter's shim with a thicker one. • When the control lever is depressed toward the "idling" position, replace the shifter's shim with a thinner one. 		
Rack Limiter Adjustment	100	13.2	

A6

ZEXEL - Test values
Injection pumps



A7

ZEXEL - Test values
Injection pumps



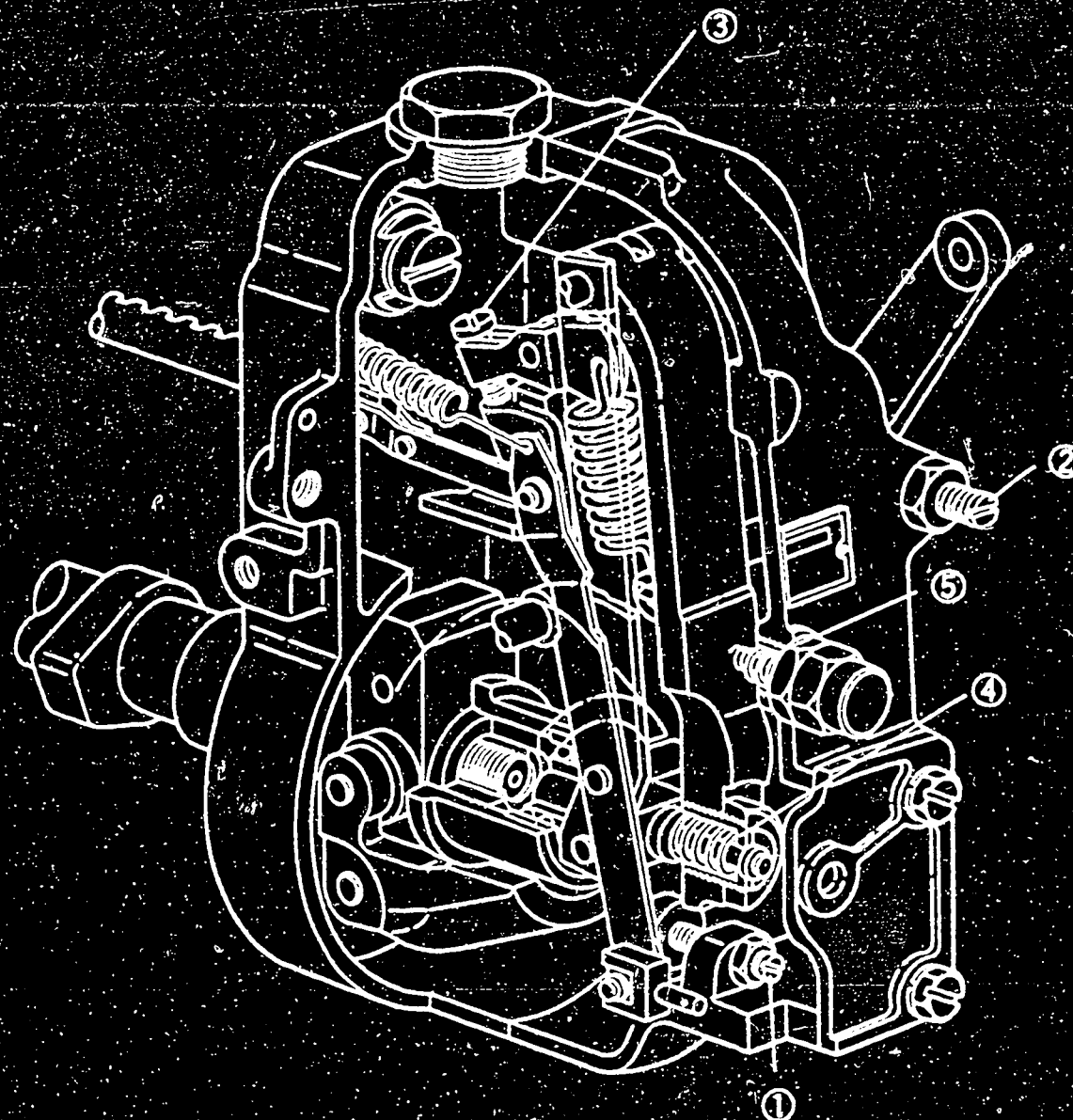

Figure 2

- 1 = Screw
- 2 = Screw
- 3 = Screw
- 4 = Spring capsule
- 5 = Spring capsule

■ Note

- Before adjustment, remove the idling sub spring.
- Move the control lever fully in the stop direction, and set the minimum-speed stopper bolt so that the control rack position is 0.5 - 1.0 mm.

A8

ZEXEL - Test values
Injection pumps



A9

ZEXEL - Test values
Injection pumps



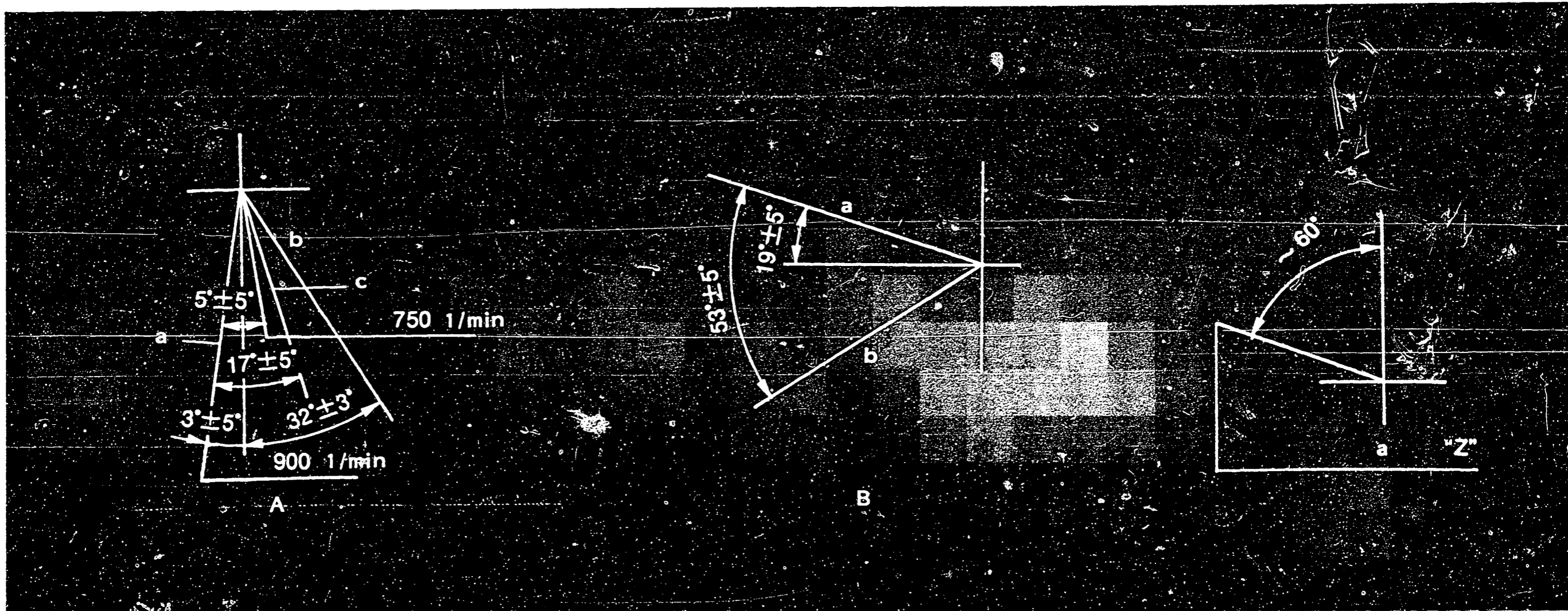

Figure 3

101472-0080 3/3

A = Speed Control Lever Angle

B = Stop Lever Angle

a = Full-speed

a = Normal

a = Mark

b = Stop

b = Stop

c = Idling

■ TIMING SETTING

At No. 4 plunger's beginning of injection position

B.T.D.C.: 16°

A10

ZEXEL - Test values
Injection pumps



A11

ZEXEL - Test values
Injection pumps



ZEXEL - TEST VALUES
Injection pumps

BOSCH No.	:	9 400 610 154	1/4
ZEXEL No.	:	101491-0265	
Date	:	30.09.1991	[7]
Company	:	ISUZU	
Engine	:	4BC2 / 8-94139-019-5	
IP-Type number	:	101049-8510	/ PES4A
Governor type number	:	105931-5450	/ EP/RLD

TEST PREREQUISITES

Test oil	:	ISO-4113
Test oil inlet temperature °C	:	40.00...45.00
Inlet pressure bar	:	1.6
Test nozzle holder combination	:	1 688 901 013
Opening pressure bar	:	175
Test pressure line	:	
Inner x Outer Dia - Length mm	:	2.00 x 6.00 x 600

PORT CLOSING

Prestroke mm	:	3.4 ± 0.05
Rod position mm	:	-
Port closing mark Cyl. No.	:	-
Cam sequence	:	1 - 3 - 4 - 2
Port closing mark Cyl. No.	:	-
Port closing difference °NW	:	0-90-180-270
Tolerance +- °C	:	0.50 (0.75)



Injection Quantity :

Adjusting Point	Rod Pos. (mm)	Speed (rpm)	Injection Q'ty (cc/1000 str.)	Difference (%)	Fixed	Remarks
	10.2	1100	47.6 - 50.8	± 2.5	Rack	Basic
H	approx. 9.9	300	8.0 - 11.0	± 14	Rack	
A	R ₁ (10.2)	1100	48.2 - 50.2	-	Lever	Basic
B	R ₁ -0.1	1800	(44.9 - 48.1)	-	Lever	
C	R ₁ +0.1	700	(38.2 - 41.4)	-	Lever	
D	R ₁ ±0.7	500	-	-	Lever	
I	-	100	52.5 - 62.5	-	Lever	Control rack limit

Timing Advance Specification:

Speed (rpm)	below 1650	1600	1800	1900			
Advance Angle (deg)	START	below 0.6	2.5-3.5	4.0-5.0	Finish (0.5)		

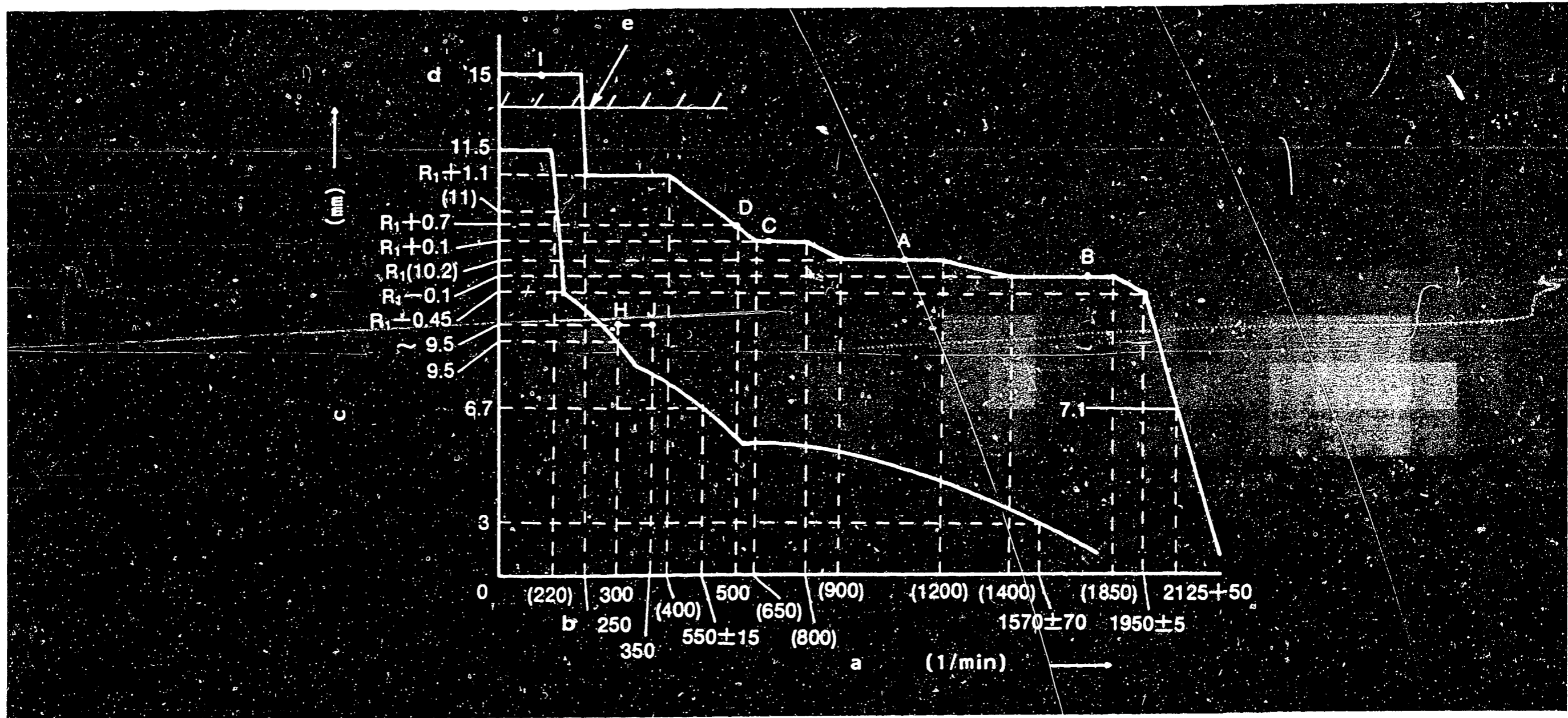

Figure 4

GOVERNOR ADJUSTMENT - (Full Load Adjustment)

101491-0265 2/4

- a = Pump speed
- b = below
- c = Control rack position
- d = above
- e = Control rack limit

A15

ZEXEL - Test values
Injection pumps



A16

ZEXEL - Test values
Injection pumps



	Pump speed (rpm)	Rack position (mm)	Remarks
Idling Lever Position temporary setting	80 - 100	11.5	• Adjust using screw (1)
Idling Adjustment	300 (220)	9.5 (11.0)	• Adjust using screw (1) • Adjust using screw (2)
Governor Spring Contact Adjustment	535 - 565	6.7	• Adjust the governor shaft position
	1500 - 1640	3.0	• Confirm
Setting the Idling Lever Position	300	approx. 9.5	• Adjust using screw (1) • Confirm the control lever angle (0.5°-10.5°)

	Speed (rpm)	Rack position (mm)	Remarks
Full Speed Lever Position temporary setting	approx. 1950	(10.2) -0.45	• Adjust using screw (3)
Full Load Position Adjustment	1100	(10.2)	• Adjust using screw (4)
Torque Cam Position Adjustment	500	(10.2) +0.7	• Adjust using screw (5)
	(400)	(10.2) +1.1	• Confirm
	(650)	(10.2) +0.1	• Confirm
	(800)	(10.2) +0.1	• Confirm
	(900)	(10.2)	• Confirm
	(1200)	(10.2)	• Confirm
	(1400)	(10.2) -0.1	• Confirm
	(1850)	(10.2) -0.1	• Confirm
Confirm injection quantity at points A to C			
Maximum Speed Control Adjustment	1945 - 1955	(10.2) -0.45	• Adjust using screw (3)
	2075 - 2175	7.1	• Confirm • After adjustment confirm that the control lever angle is 34° - 40°
Confirming Excess Fuel Limit for Engine Starting	350	approx. 9.5	• Set the control lever at point J
	0	11.5	• Confirm
	0	above 15	• Move the control lever to the "full speed" position and then confirm the control rack position
Confirm the Black Smoke Limit	Fix the control lever at point H. Then operate the pump at 250 rpm. Confirm that the control rack does not move beyond (10.2)+1.1 mm. When the control lever is moved to the "full speed" position, again increase the pump speed and confirm that the control rack starts to move from a pump speed of 400 rpm.		
Rack Limiter Adjustment	100	-	• Fix the control rack using screw.
	Measure the depth of the control rack cap. Then adjust screw (6) so that it equals the depth of the rack cap and install the rack cap. Confirm injection quantity at point J.		

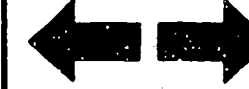

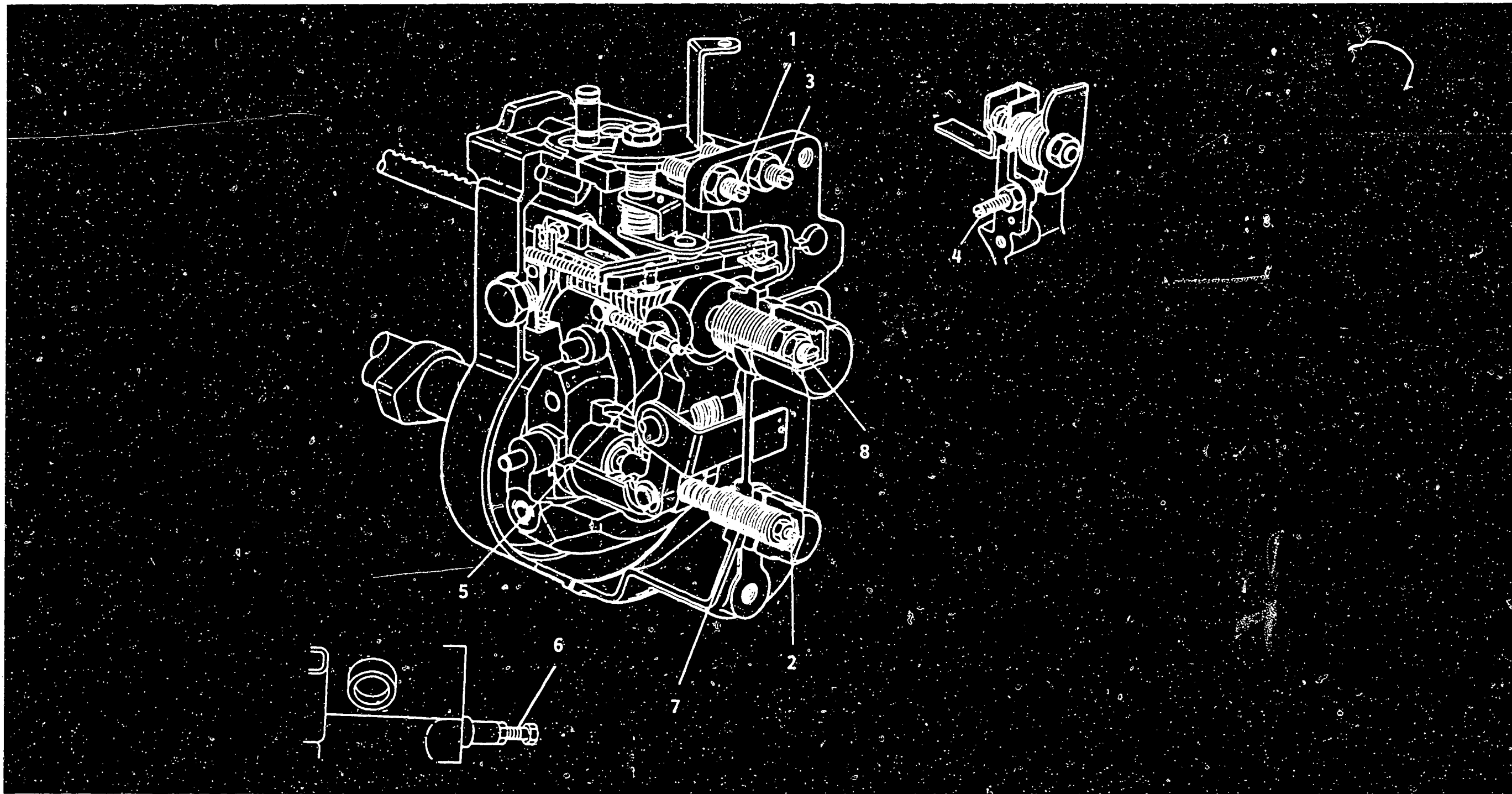

Figure 5

101491-0265 4/4

- 1 = Screw
- 2 = Screw
- 3 = Screw
- 4 = Screw

- 5 = Screw
- 6 = Screw
- 7 = Spring capsule
- 8 = Governor shaft



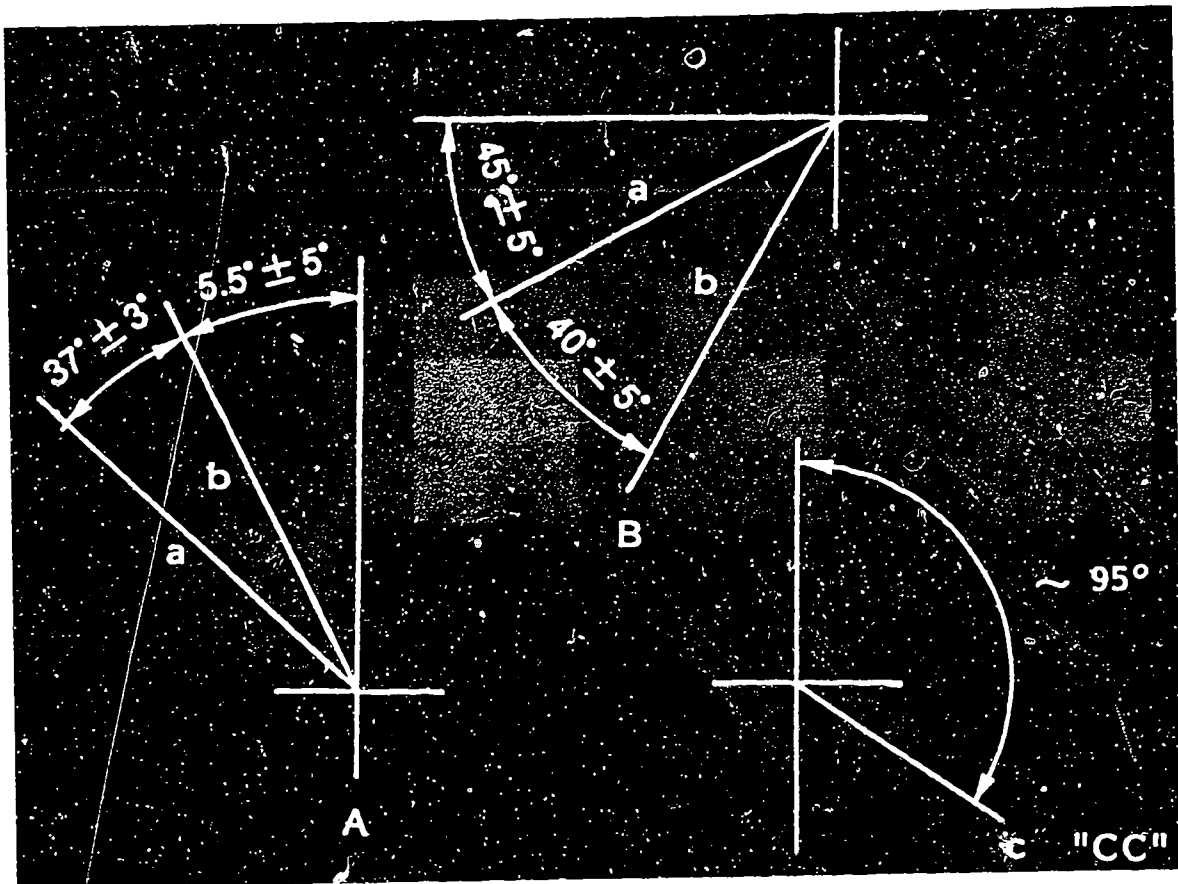

Figure 6

101491-0265 4/4

A = Speed Control Lever Angle

a = Full speed

b = Idling

B = Stop Lever Angle

a = Normal

b = Stop

c = Mark

TIMING SETTING

At No. 1 plunger's beginning of injection position
B.T.D.C.: 15°.

A23

ZEXEL - Test values

Injection pumps



ZEXEL - TEST VALUES
Injection pumps

BOSCH No. : 9 400 610 155 1/3
ZEXEL No. : 101491-1101
Date : 30.09.1991 [2]
Company : MITSUBISHI
Engine : 4D31T / ME017759

IP-Type number : 101049-9031 / PES4A
Governor type number : 105402-1950 / EP/RSV

TEST PREREQUISITES

Test oil : ISO-4113
Test oil inlet temperature °C : 40.00...45.00
Inlet pressure bar : 1.6
Test nozzle holder combination : 1 688 901 013
Opening pressure bar : 175
Test pressure line
Inner x Outer Dia - Length mm : 2.00 x 6.00 x 600

PORT CLOSING

Prestroke mm : 3,2 ± 0.05
Rod position mm : -
Port closing mark Cyl. No. : -
Cam sequence : 1 - 3 - 4 - 2

Port closing mark Cyl. No. : -
Port closing difference °NW : 0-90-180-270

Tolerance +- °C: 0.50 (0.75)

B1

ZEXEL - Test values
Injection pumps



Injection Quantity :

Adjusting Point	Rod Pos. (mm)	Speed (rpm)	Injection Q'ty (cc/1000 str.)	Difference (%)	Fixed	Remarks
A	9.7	1000	63.5 - 65.5	± 2.5	Rack	Basic
H	approx. 8.2	375	6.2 - 8.8	± 1 ⁴	Rack	
A	9.7	1000	63.5 - 65.5	-	Lever	Basic
C	(11.6)	100	60.5 - 65.5	-	Lever	
D	approx. 7.6	700	7.0 - 9.0	± 15	Rack	

Timing Advance Specification : EP/SCDM
105676-0090

Speed (rpm)	below 1270	1200	1500				
Advance Angle (deg)	START	below 0.5	1.2-1.8				

B2

ZEXEL - Test values
Injection pumps



B3

ZEXEL - Test values
Injection pumps



	Pump Speed (rpm)	Rack Position (mm)	Remarks
Full-load Adjustment (Temporary)	1540 - 1560 1000	9.7 9.7	<ul style="list-style-type: none"> • Adjust using screw (1) • Adjust using screw (2)
Idling Adjustment	0 375	above 14 7.0	<ul style="list-style-type: none"> • Fix the control lever • Adjust using spring capsule (3) • Confirm
Maximum-speed Adjustment	990 - 1010 1030 - 1035	9.7 7.7	<ul style="list-style-type: none"> • Adjust using screw (1) • Confirm speed droop
Full-load Adjustment (install the cover on governor cover)	1000	9.7	<ul style="list-style-type: none"> • Adjust using screw (2)
Control Lever Angle Measurement	<ul style="list-style-type: none"> • Measure the control lever angle at the "idling" and "full" positions. • When the control lever is depressed toward the "full" position, replace the shifter's shim with a thicker one. • When the control lever is depressed toward the "idling" position, replace the shifter's shim with a thinner one. 		
Rack Limiter Adjustment	(11.6)	100	

B6

ZEXEL - Test values
Injection pumps



B7

ZEXEL - Test values
Injection pumps



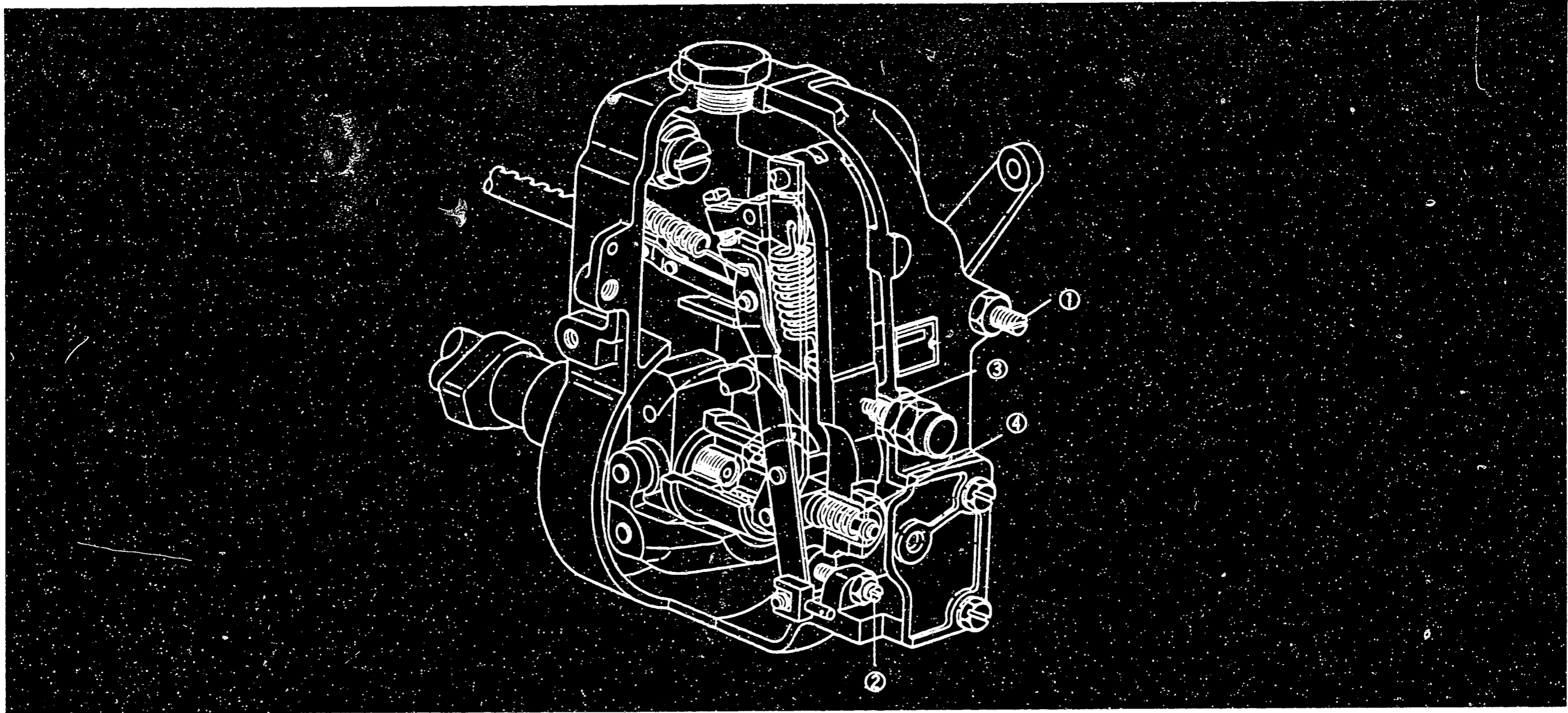

Figure 8

101491-1101 3/3

- 1 = Screw
- 2 = Screw
- 3 = Spring capsule
- 4 = Spring capsule

■ Note

- Before adjustment, remove the idling sub spring.
- Move the control lever fully in the stop direction, and set the minimum-speed stopper bolt so that the control rack position is 0.5 - 1.0 mm.

B8

ZEXEL - Test values
Injection pumps



B9

ZEXEL - Test values
Injection pumps



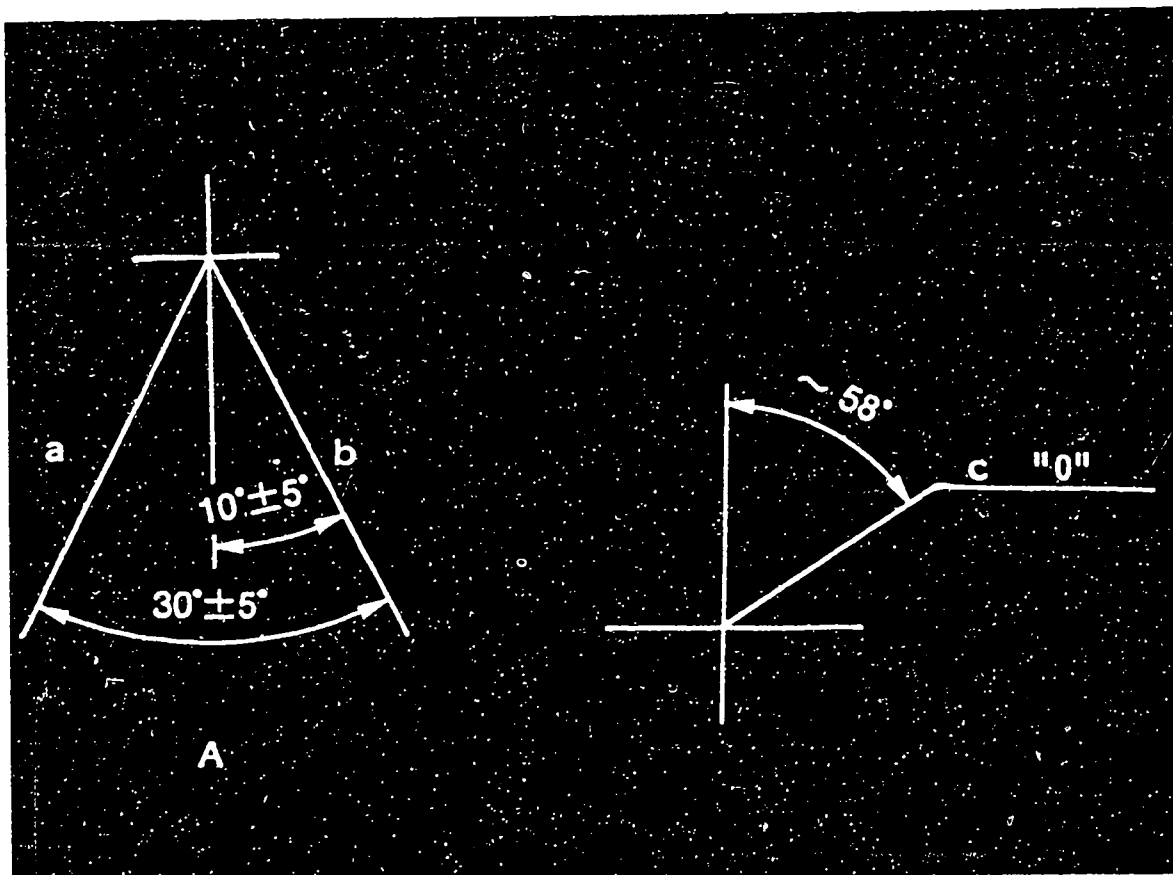

Figure 9

101491-1101 3/3

A = Speed Control Lever Angle

a = Idling

b = Full-speed

■ TIMING SETTING

At No. 1 plunger's beginning of injection position
B.T.D.C.: 16°

B10

ZEXEL - Test values

Injection pumps



ZEXEL - TEST VALUES
Injection pumps

BOSCH No.	:	9 400 610 150	1/4
ZEXEL No.	:	101602-9510	
Date	:	30.09.1991	[2]
Company	:	NISSAN DIESEL	
Engine	:	FD6 / 16713-L9204	

IP-Type number	:	101060-9631 / PES6A
Governor type number	:	105921-0481 / EP/RLD

TEST PREREQUISITES

Test oil	:	ISO-4113
Test oil inlet temperature °C	:	40.00...45.00
Inlet pressure bar	:	1.6
Test nozzle holder combination	:	1 688 901 013
Opening pressure bar	:	175
Test pressure line	:	
Inner x Outer Dia - Length mm	:	2.00 x 6.00 x 600

PORT CLOSING

Prestroke	mm	:	3.0 ± 0.05
Rod position	mm	:	-
Port closing mark Cyl. No.	:	:	-
Cam sequence	:	:	1-4-2-6-3-5
Port closing mark Cyl. No.	:	:	-
Port closing difference °NW	:	:	0-60-120-180-240-300
Tolerance	+ - °C	:	0.50 (0.75)

B11

ZEXEL - Test values
Injection pumps



Injection Quantity :

Adjusting Point	Rod Pos. (mm)	Speed (rpm)	Injection Q'ty (cc/1000 str.)	Difference (%)	Fixed	Remarks
	10.1	1000	47.1 - 50.3	± 3.5	Rack	Basic
H	approx. 9.8	335	6.2 - 9.8	± 10	Rack	
A	R (10.1)	1000	47.7 - 49.7	-	Lever	Basic
I	approx. 12.0	100	62.0 - 72.0	-	Lever	

Timing Advance Specification:

Speed (rpm)							
Advance Angle (deg)							

B12

ZEXEL - Test values

Injection pumps



B13

ZEXEL - Test values

Injection pumps



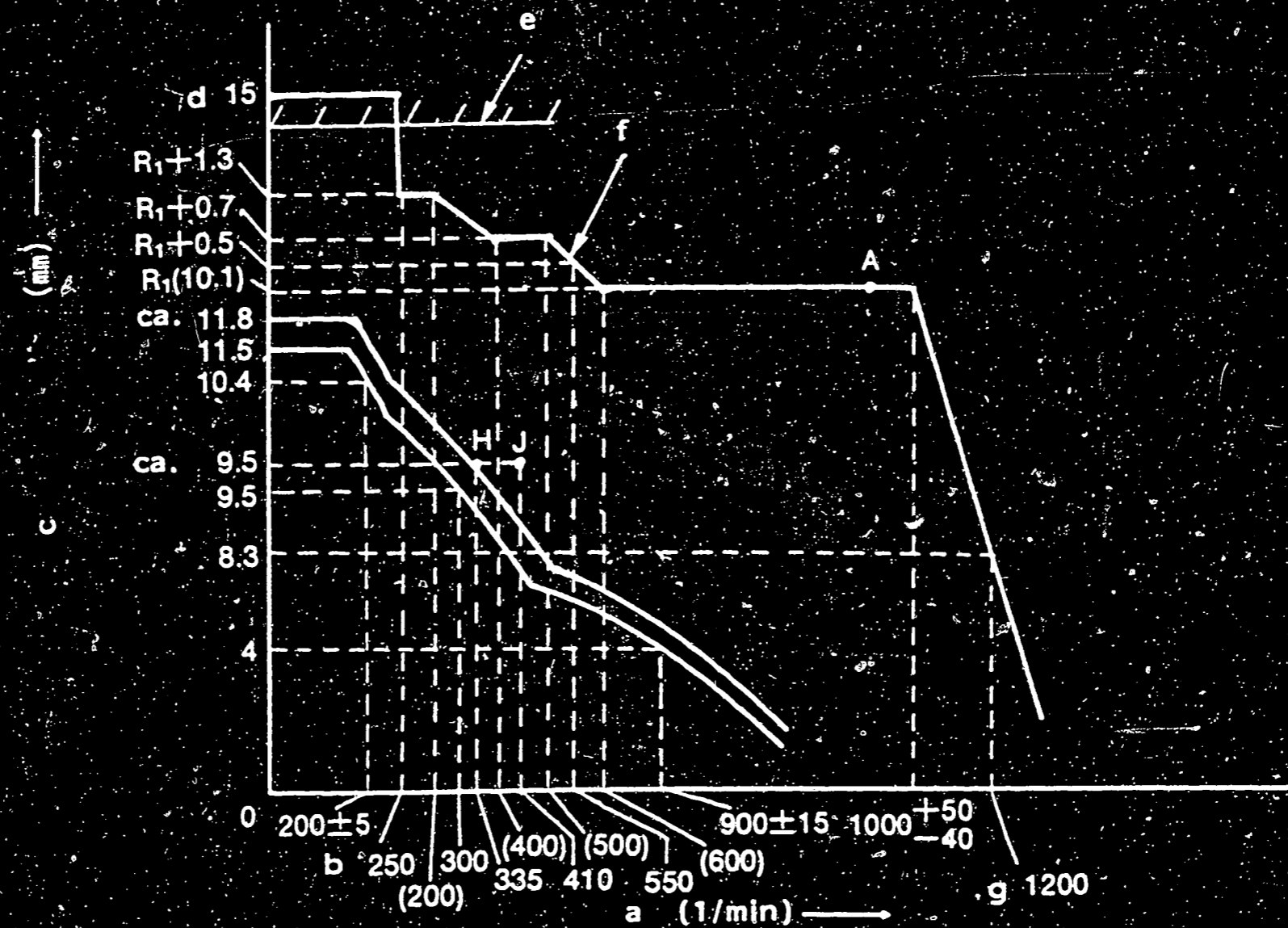

Figure 10

GOVERNOR ADJUSTMENT

- a = Pump speed
- b = below
- c = Control rack position
- d = above

- e = Control rack limit: approx. 12
- f = (Basic torque cam adjustment)
- g = below

B14

ZEXEL - Test values
Injection pumps



B15

ZEXEL - Test values
Injection pumps



	Pump speed (rpm)	Rack position (mm)	Remarks
Idling Lever Position temporary setting	80 - 100	11.5	• Adjust using screw (1)
Idling Adjustment	300	9.5	• Adjust using spring capsule (7)
	215 - 225	10.4	• Adjust using screw (2)
Governor Spring Contact Adjustment	-	-	• Adjust the governor shaft position • Confirm
Setting the Idling Lever Position	335	approx. 9.5	• Adjust using screw (1) • Confirm the control lever angle (12° - 22°)

B16

ZEXEL - Test values
Injection pumps



B17

ZEXEL - Test values
Injection pumps



	Speed (rpm)	Rack position (mm)	Remarks
Full Speed Lever Position temporary setting	1040 - 1050	(10.1) -0.1	• Adjust using screw (3)
Full Load Position Adjustment	1000	47.7 - 49.7	• Adjust using screw (4)
Torque Cam Position Adjustment	550	(10.1) +0.5	• Adjust using screw (5)
	(600)	(10.1)	• Confirm
	(400)	(10.1) +0.7	• Confirm
	(280)	(10.1) +1.3	• Confirm
Confirm injection quantity at points A to C			
Maximum Speed Control Adjustment	1040 - 1050 below 1200	(10.2) -0.5 8.3	• Adjust using screw (3) • Confirm • After adjustment confirm that the control lever angle is 27° - 33°
Confirming Excess Fuel Limit for Engine Starting	410 0 0	approx. 9.5 11.4 - 11.6 above 15	• Set the control lever at point J • Confirm • Move the control lever to the "full speed" position and then confirm the control rack position
Confirm the Black Smoke Limit	Fix the control lever at point H. Then operate the pump at 270 rpm. Confirm that the control rack does not move beyond (10.1)+1.3 mm. When the control lever is moved to the "full speed" position, again increase the pump speed and confirm that the control rack starts to move from a pump speed of 300 rpm.		
Rack Limiter Adjustment	100	above 12	• Fix the control rack using screw.
	Measure the depth of the control rack cap. Then adjust screw (6) so that it equals the depth of the rack cap and install the rack cap. Confirm injection quantity at point J.		



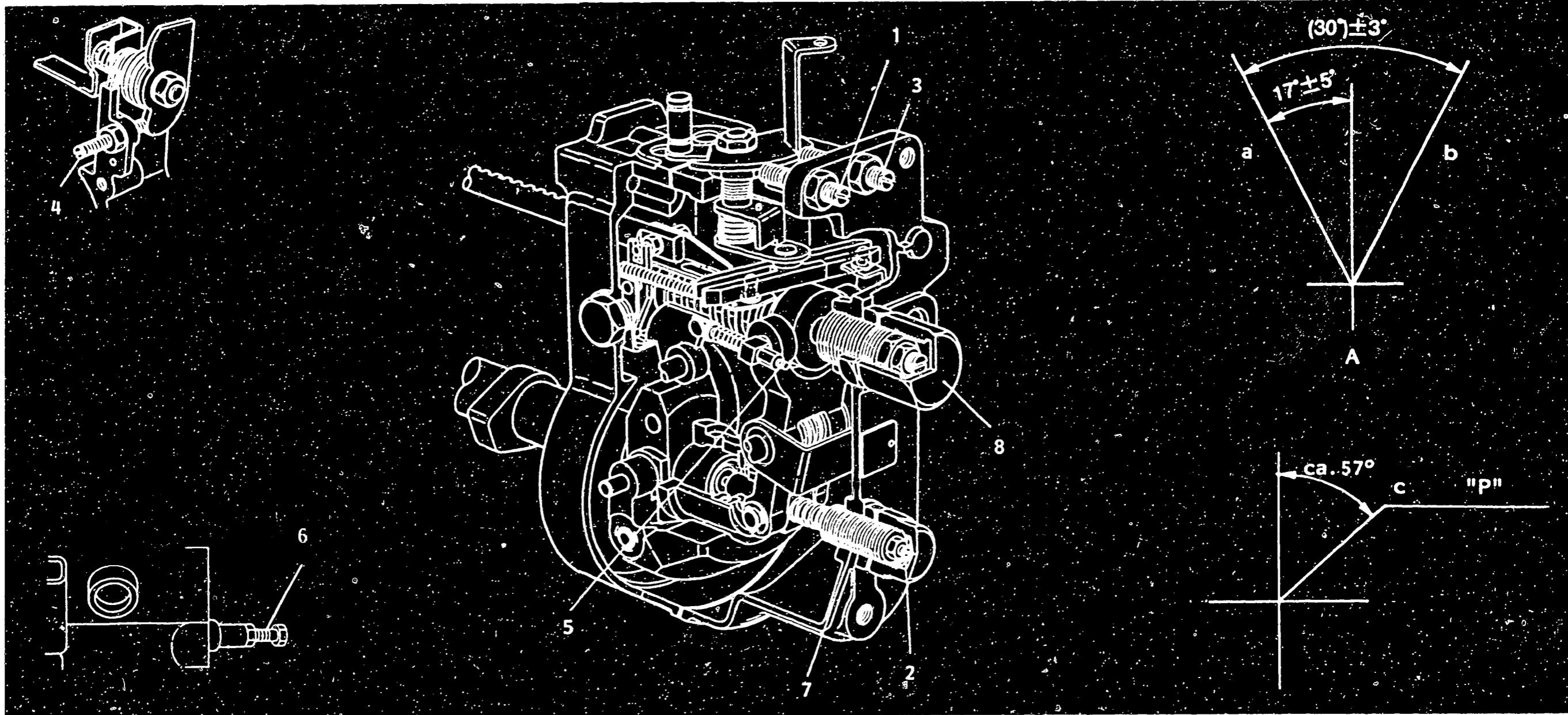

- 1 = Screw
- 2 = Screw
- 3 = Screw
- 4 = Screw

■ TIMING SETTING

At No. 1 plunger's beginning of injection position B.T.D.C.: 18.5°.

Figure 11

- 5 = Screw
- 6 = Screw
- 7 = Spring capsule
- 8 = Governor shaft

A = Speed Control Lever Angle

- a = Idling
- b = Full-speed

c = Mark

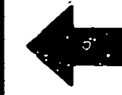

ZEXEL - TEST VALUES
Injection pumps

BOSCH No.	:	9 400 610 147	1/4
ZEXEL No.	:	101631-9870	
Date	:	30.09.1991	[1]
Company	:	NISSAN DIESEL	
Engine	:	SD33 / 16790-90263	
IP-Type number	:	101063-9390	/ PES6A
Governor type number	:	105410-9130	/ EP/RSV

TEST PREREQUISITES

Test oil	:	ISO-4113
Test oil inlet temperature °C	:	40.00...45.00
Inlet pressure	bar :	1.6
Test nozzle holder combination	:	1 688 901 013
Opening pressure	bar :	175
Test pressure line		
Inner x Outer Dia - Length	mm :	2.00 x 6.00 x 600

PORT CLOSING

Prestroke	mm :	2.3 ± 0.05
Rod position	mm :	-
Port closing mark	Cyl. No. :	-
Cam sequence	:	1-4-2-6-3-5
Port closing mark	Cyl. No. :	-
Port closing difference	°NW :	0-60-120-180-240-300
Tolerance	+ - °C :	0.50 (0.75)

C1

ZEXEL - Test values
Injection pumps



Continued (Test values)

Injection Quantity :

Adjusting Point	Rod Pos. (mm)	Speed (rpm)	Injection Q'ty (cc/1000 str.)	Difference (%)	Fixed	Remarks
A	14.4	900	33.4 - 35.4	± 2.5	Rack	Basic
	approx. 10.4	350	6.4 - 8.6	± 15	Rack	
A	14.4	900	33.4 - 35.4	-	Lever	Basic
B	14.1	1100	32.5 - 35.5	-	Lever	
C	16.7	100	-	-	Lever	Control rack limit

Timing Advance Specification: EP/SCD
105622-0250

Speed (rpm)	below 550	500	700	1100			
Advance Angle (deg)	START	below 0.5	0.5-1.5	2.0-3.5	Finish (7.5)		

C2

ZEXEL - Test values
Injection pumps



C3

ZEXEL - Test values
Injection pumps



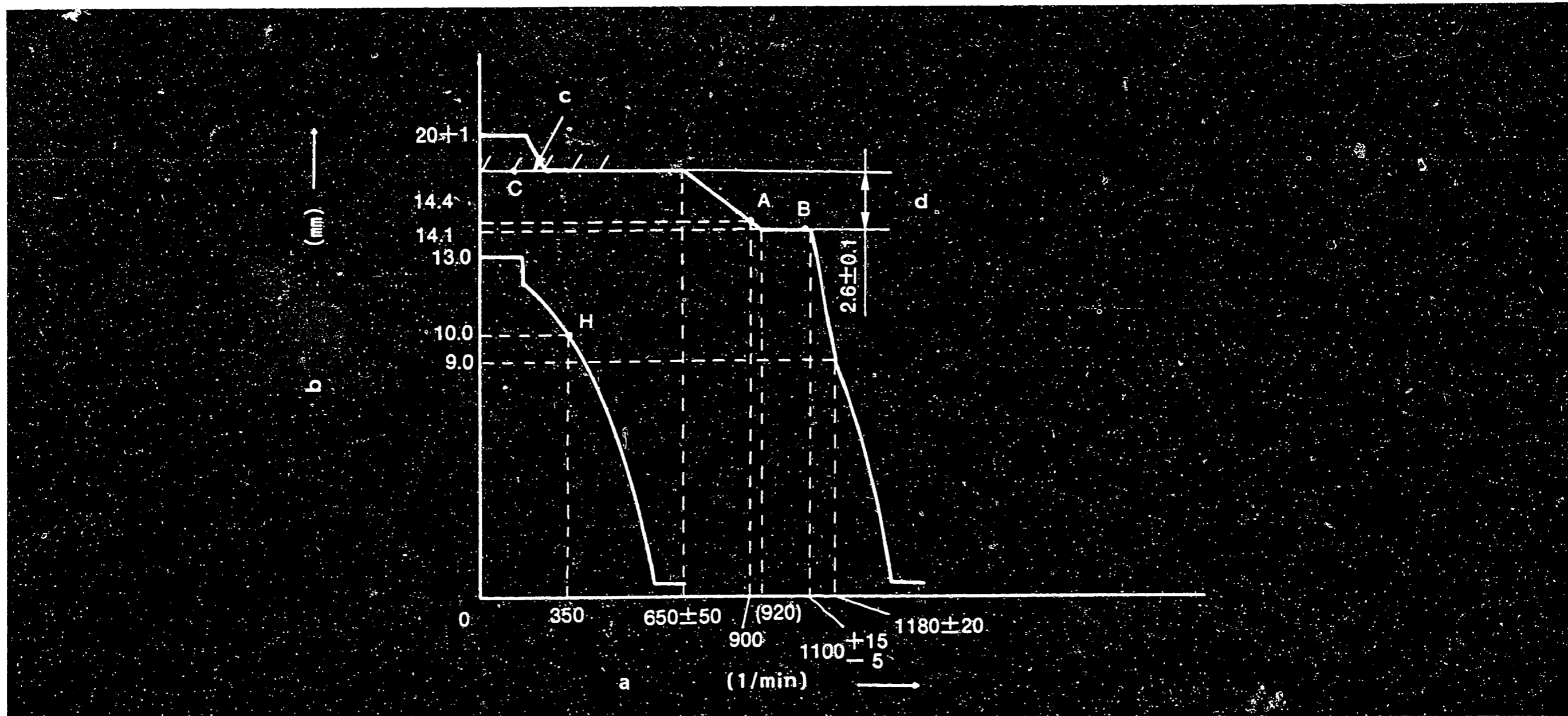

Figure 12 GOVERNOR ADJUSTMENT

Recommended speed droop adjustment screw position: 12

101631-9870 2/4

- a = Pump speed
- b = Control rack position
- c = Control rack limit: approx. 16.7
- d = Difference in control rack position between 1100 rpm and 600 rpm

■ Note

- Before adjustment, remove the idling sub spring.
- Move the control lever fully in the stop direction, and set the minimum-speed stopper bolt so that the control rack position is 0.5 - 1.0 mm.

C4

ZEXEL - Test values
Injection pumps

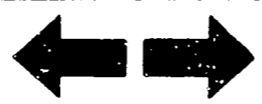

C5

ZEXEL - Test values
Injection pumps



	Pump speed (rpm)	Rack position (mm)	Remarks
Full-load Adjustment (Temporary)	1105 - 1115 (920)	14.1 14.1	<ul style="list-style-type: none"> • Adjust using screw (1). • Confirm
Torque Control spring Adjustment	approx. 600 900 1000	16.7 14.4 14.1	<ul style="list-style-type: none"> • Adjust using spring cap. (4) • Confirm • Confirm the torque control stroke is 2.5 - 2.7 mm
Idling Adjustment	0 350 -	13.0 10.0 -	<ul style="list-style-type: none"> • Fix the control lever • Adjust using spring cap. (5) • Confirm
Maximum Speed Adjustment	1105 - 1115 1120 - 1160	14.1 9.0	<ul style="list-style-type: none"> • Adjust using screw (1) • Confirm speed droop • Confirm • Confirm
Full-load Adjustment (Install the cover on governor cover)	1105 - 1115	14.1	<ul style="list-style-type: none"> • Adjust using screw (3)
Rack Limiter Adjustment	100	approx. 16.7	<ul style="list-style-type: none"> • Adjust using screw
Control Lever Angle Measurement	<ul style="list-style-type: none"> • Measure the control lever angle at the "idling" and "full" positions. • When the control lever is depressed toward the "full" position, replace the shifter's shim with a thicker one. • When the control lever is depressed toward the "idling" position, replace the shifter's shim with a thinner one. 		

C6ZEXEL - Test values
Injection pumps**C7**ZEXEL - Test values
Injection pumps

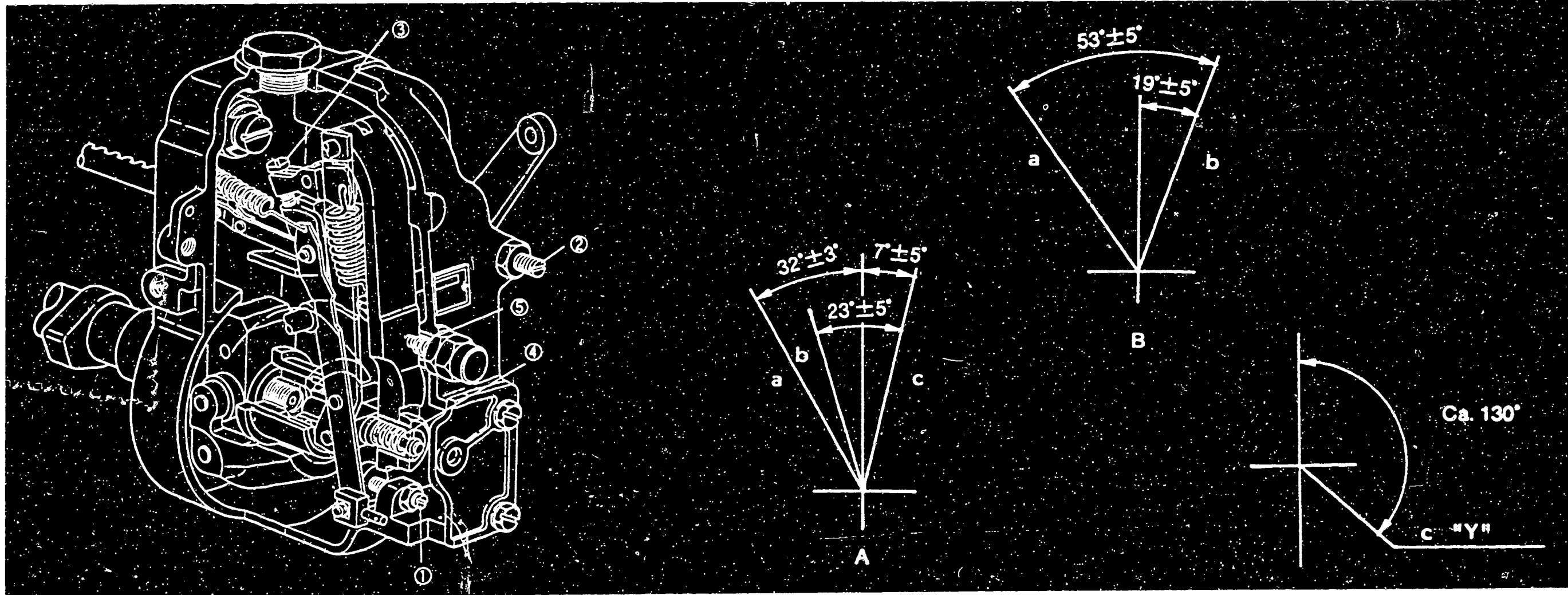

Figure 13

101631-9870 3/4
4/4

- 1 = Screw
- 2 = Screw
- 3 = Screw
- 4 = Spring capsule
- 5 = Spring capsule

A = Speed Control Lever Angle

B = Stop Lever Angle

- a = Stop
- b = Idling
- c = Full-speed

- a = Stop
- b = Normal

c = Mark

■ TIMING SETTING

At No. 1 plunger's beginning of injection position B.T.D.C.: 22°.

C8

ZEXEL - Test values
Injection pumps



C9

ZEXEL - Test values
Injection pumps



ZEXEL - TEST VALUES
Injection pumps

BOSCH No.	:	9 400 610 148	1/3
ZEXEL No.	:	104304-3161	
Date	:	30.09.1991	[2]
Company	:	ISUZU	
Engine	:	4FA1 / 5-15601-414-2	

IP-Type number	:	104300-4211 / PES4K
Governor type number	:	-

TEST PREREQUISITES

Test oil	:	ISO-4113
Test oil inlet temperature °C	:	40.00...45.00
Inlet pressure bar	:	1.6
Test nozzle holder combination	:	1 688 901 013
Opening pressure bar	:	175
Test pressure line	:	
Inner x Outer Dia - Length mm	:	2.00 x 6.00 x 600

PORT CLOSING

Prestroke	mm	:	2.1 ± 0.05
Rod position	mm	:	-
Port closing mark Cyl. No.	:	:	-
Cam sequence	:	:	1 - 3 - 4 - 2

Port closing mark Cyl. No.	:	:	-
Port closing difference °NW	:	:	0-90-180-270

Tolerance	+ - °C	:	0.50 (0.75)
-----------	--------	---	-------------

C10

ZEXEL - Test values
Injection pumps



Continued (Test values)

Injection Quantity :

Adjusting Point	Rod Pos. (mm)	Speed (rpm)	Injection Q'ty (cc/1000 str.)	Difference (%)	Fixed	Remarks
A	8.1	1000	26.5 - 27.5	± 2.5	Rack	Basic
H	approx. 6.0	350	7.0 - 9.0	± 14	Rack	
A	8.1	1000	26.5 - 27.5	-	Lever	Basic
B	7.5	1375	(25.0 - 27.0)	-	Lever	

Timing Advance Specification :

Speed (rpm)							
Advance Angle (deg)							

C11

ZEXEL - Test values
Injection pumps



C12

ZEXEL - Test values
Injection pumps



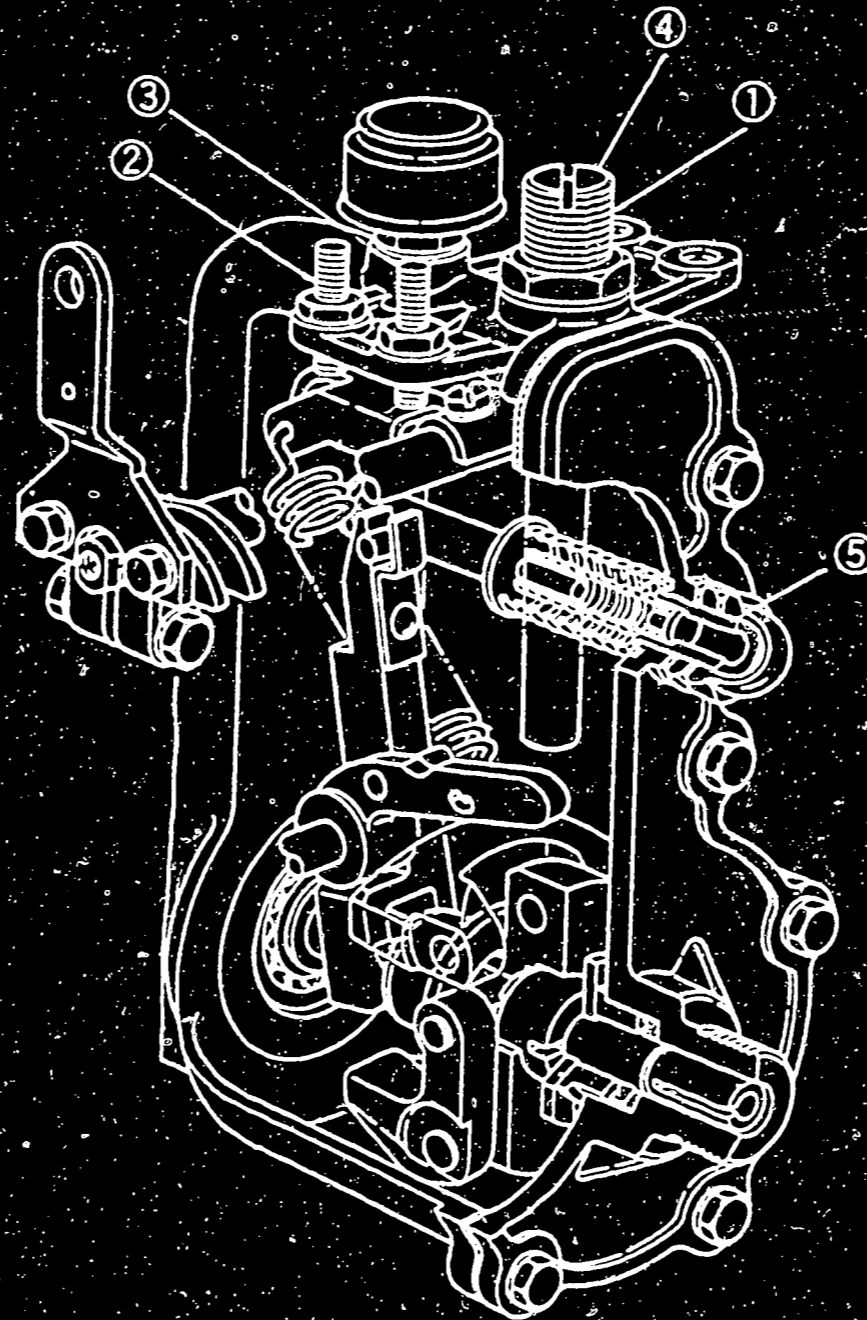

Figure 15
1 = Screw
2 = Screw
3 = Screw
4 = Screw
5 = Idling spring guide

104304-3161 3/3

C15

ZEXEL - Test values
Injection pumps



C16

ZEXEL - Test values
Injection pumps



	Pump Speed (rpm)	Rack Position (mm)	Remarks
Full-load Adjustment (temporary)	(1430) 1375	7.3 - 7.5 7.5	<ul style="list-style-type: none"> • Adjust using screw (1) • Confirm injection quantity at point B
Maximum Speed Adjustment	Fix the control lever in the full-speed position		
	1500 - 1550 (1430)	4.0 7.3 - 7.5	<ul style="list-style-type: none"> • Confirm • Adjust using screw (2)
Idling Adjustment	325	6.0	<ul style="list-style-type: none"> • Adjust using idling spring guide (5)
	350	6.0	<ul style="list-style-type: none"> • Move the control lever
	0	13 + 1	<ul style="list-style-type: none"> • Confirm
Stopper Bolt Adjustment	100	13.0 - 14.0	<ul style="list-style-type: none"> • Adjust using screw (3)
Torque Control Spring Adjustment	(1430) 1375 1100 - 1200	7.3 - 7.5 7.5 8.1	<ul style="list-style-type: none"> • Move the control lever • Confirm • Adjust using screw (4) • Confirm the torque control stroke is 0.7 mm

C17

ZEXEL - Test values
Injection pumps



C18

ZEXEL - Test values
Injection pumps



ZEXEL - TEST VALUES
Injection pumps

BOSCH No.	:	9 400 610 153	1/3
ZEXEL No.	:	104304-4351	
Date	:	30.09.1991	[1]
Company	:	ISUZU	
Engine	:	4FE1 / 8-94400-861-0	

IP-Type number	:	104300-4490 / PES4K
Governor type number	:	-

TEST PREREQUISITES

Test oil	:	ISO-4113
Test oil inlet temperature °C	:	40.00...45.00
Inlet pressure bar	:	1.6
Test nozzle holder combination	:	1 688 901 013
Opening pressure bar	:	175
Test pressure line	:	
Inner x Outer Dia - Length mm	:	2.00 x 6.00 x 600

PORT CLOSING

Prestroke mm	:	2.1 ± 0.05
Rod position mm	:	-
Port closing mark Cyl. No.	:	-
Cam sequence	:	1 - 3 - 4 - 2

Port closing mark Cyl. No.	:	-
Port closing difference °NW	:	0-90-180-270

Tolerance +- °C	:	0.50 (0.75)
-----------------	---	-------------



Continued (Test values)

Injection Quantity :

Adjusting Point	Rod Pos. (mm)	Speed (rpm)	Injection Q'ty (cc/1000 str.)	Difference (%)	Fixed	Remarks
A	8.2	1000	(24.9 - 26.9)	± 2.5	Rack	Basic
H	approx. 6.6	350	6.6 - 8.6	± 14	Rack	
A	8.2	1000	24.9 - 26.9	-	Lever	Basic
B	7.8	1250	(25.9 - 27.9)	-	Lever	
C	13 + 1	100	above 34.4	-	Lever	

Timing Advance Specification :

Speed (rpm)							
Advance Angle (deg)							

C20

ZEXEL - Test values
Injection pumps



C21

ZEXEL - Test values
Injection pumps



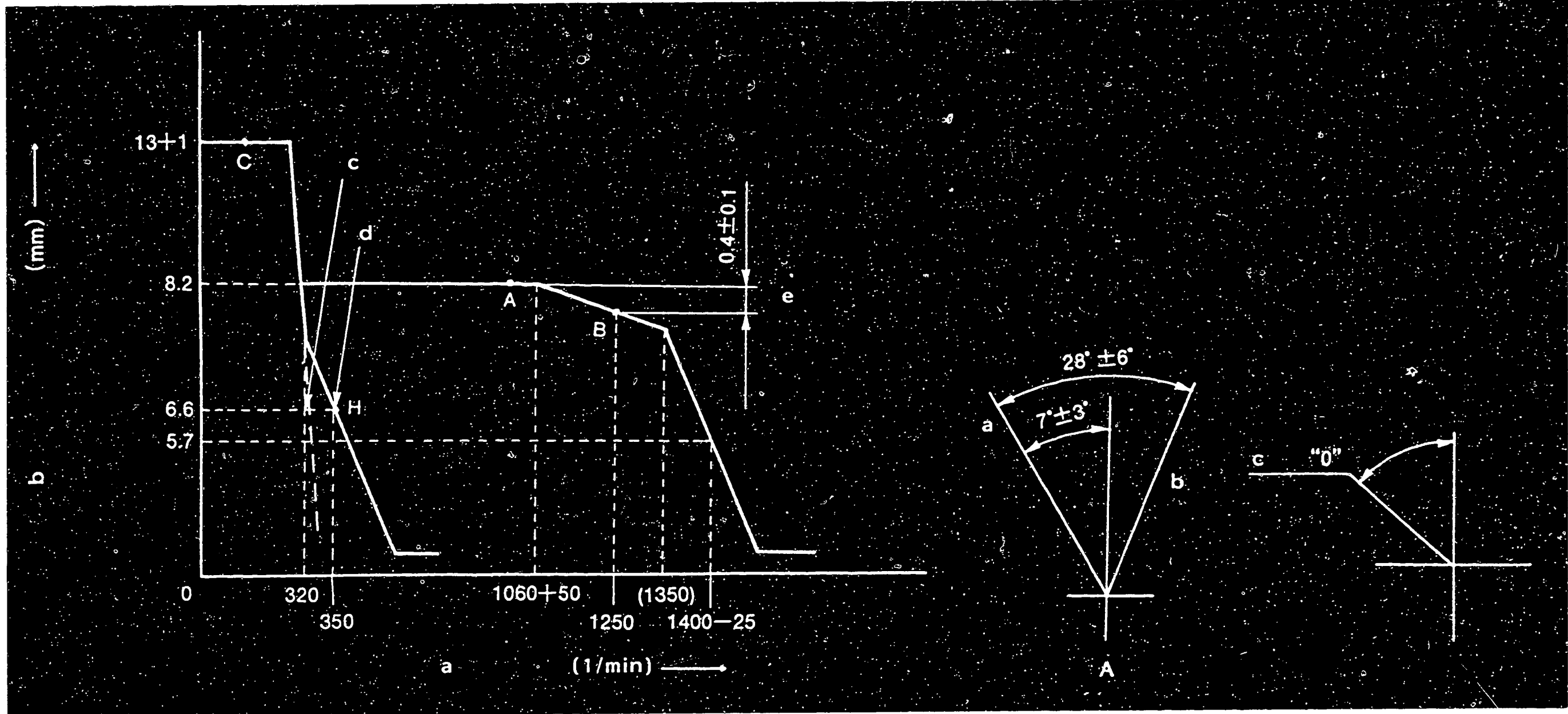

Figure 16

GOVERNOR ADJUSTMENT

- a = Pump speed
- b = Control rack position
- c = Idle-sub spring setting
- d = Governor spring setting
- e = Difference in control rack position between 1250 rpm and 1000 rpm

A = Speed Control Lever Angle

a = Full-speed

b = Idling

c = Mark

■ TIMING SETTING

At No. 1 plunger's beginning of injection position
B.T.D.C: 17°

C22

ZEXEL - Test values
Injection pumps



C23

ZEXEL - Test values
Injection pumps



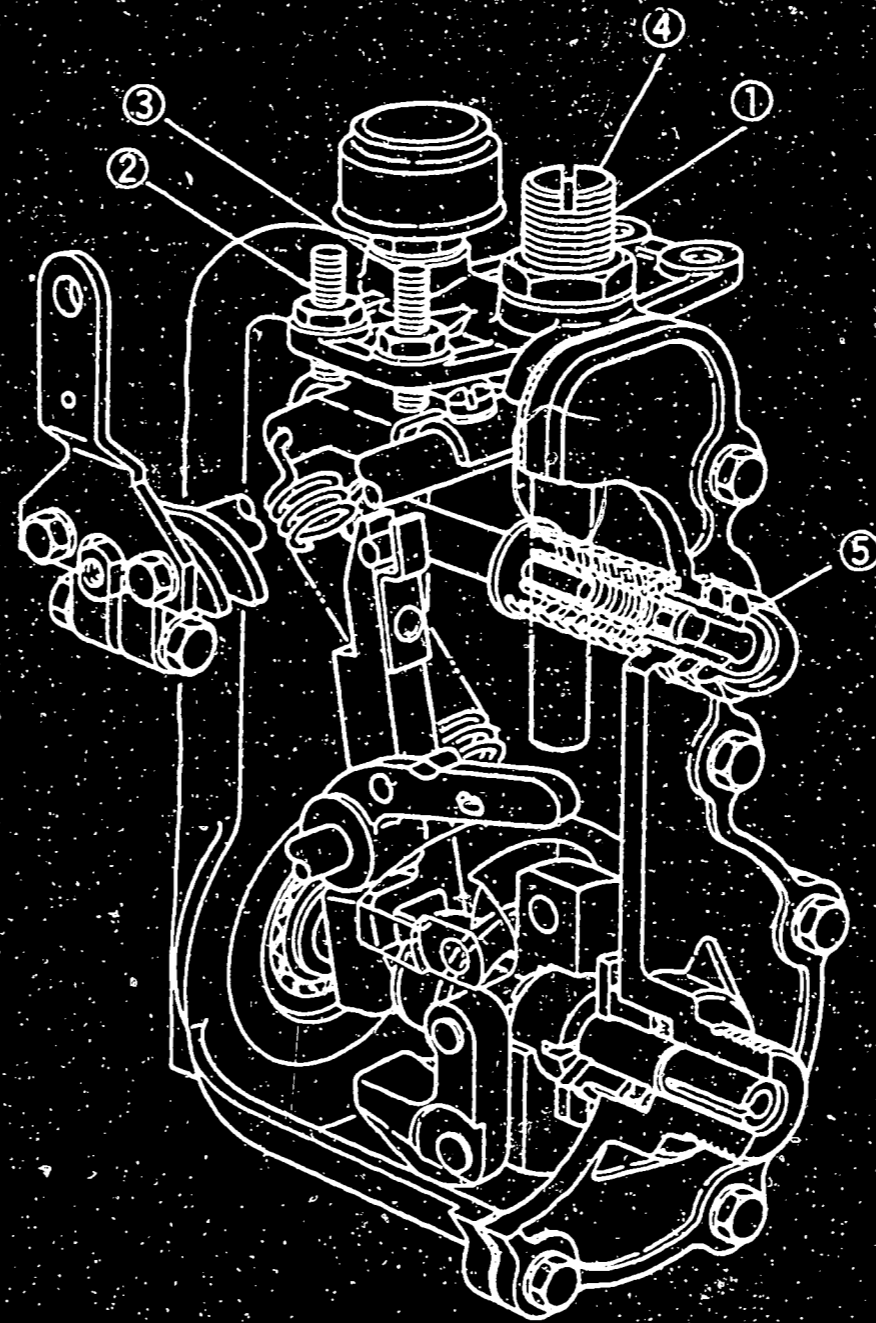

Figure 17
1 = Screw
2 = Screw
3 = Screw
4 = Screw
5 = Idling spring guide

104304-4351 3/3

C24

ZEXEL - Test values
Injection pumps



C25

ZEXEL - Test values
Injection pumps



	Pump Speed (rpm)	Rack Position (mm)	Remarks
Full-load Adjustment (temporary)	(1350)	(7.6 - 7.8)	• Adjust using screw (1)
Maximum Speed Adjustment	Fix the control lever in the full-speed position		
	1375 - 1400 (1350)	5.7 (7.6)	• Confirm • Adjust using screw (2)
Idling Adjustment	320 350 0	6.6 6.6 13 + 1	• Adjust using idling spring guide (5) • Move the control lever • Confirm
Stopper Bolt Adjustment	100	13.0 - 14.0	• Adjust using screw (3)
Torque Control Spring Adjustment	1350 1250 1010 - 1110	(7.6 - 7.8) 7.8 8.2	• Move the control lever • Confirm • Adjust using screw (4) • Confirm the torque control stroke is 0.4 mm



Test oil
ISO 4113 or
SAE J967d

ZEXEL-TEST VALUES
Distributor pumps
Engine model: C223

BOSCH No. 9 460 610 390
ZEXEL No. 104740-1032
Date: 30.09.1991 [0]
Company: ISUZU
No. 8941323381

Injection pump no.: 104640-1032

(NP-VE4/10F2175LNP260)

Pump rotation: Counter clockwise-viewed
from drive side

Test-nozzle holder combination:
1 688 901 000

Test pressure line:
1 680 750 017

1. Setting values	Speed (rpm)	Setting values	Charge-air pressure bar (mmHg)	Difference (cc)
1-1 Timing device travel	1250	2.7 - 3.1 (mm)	0	
1-2 Supply pump pressure	1250	4.6 - 5.0 (kg/cm ²)	0	
1-3 Full load delivery	1250	45.4 - 46.4 (cc/1000st)	590 - 610	4.0
1-4 Idle speed regulation	375	9.3 - 13.3 (cc/1000st)	0	2.0
1-5 Start	100	above 60.0 (cc/1000st)	0	
1-6 Full-load speed regulation	2550	19.9 - 25.9 (cc/1000st)	590 - 610	7.0
1-7				

2. Test values

2-1 Timing device	N = rpm mm	1250 2.6-3.2	1700 5.0-6.0	2150 7.9-8.6
2-2 Supply pump	N = rpm kg/cm ²	250 1.6-2.2	1250 4.6-5.0	2000 6.1-6.7
2-3 Overflow delivery	N = rpm cc/10s	1000 40.8-84.2		2150 6.4-7.0
2-4 Fuel injection quantities				
Speed control lever pos.	Speed (rpm)	Fuel delivery (cc/1000st)	Charge-air pres (mmHg)	Difference (cc)
End stop	1250	32.3 - 37.3	0	
	1250	44.9 - 46.9	590 - 610	
	600	31.4 - 36.4	0	
	900	40.4 - 42.1	590 - 610	
	1150	44.8 - 49.8	590 - 610	
	2000	37.1 - 42.1	590 - 610	
	2175	34.8 - 40.4	590 - 610	
	2550	19.4 - 26.4	590 - 610	
	2800	below 7.0	590 - 610	
Switch off	375	0	0	
Idle-stop	375	9.3 - 13.3	0	
	450	below 3.0	0	

3. Dimensions

K	3.2 - 3.4 mm
KF	5.7 - 5.9 mm
MS	1.5 - 1.7 mm
BCS	3.4 - 3.6 mm
Pre-str.	- mm
Control lever angle	
α	21° - 27° deg
A	9.2 - 11.0 mm
β	37° - 47° deg
B	12.0° - 15.0° mm
γ	- deg
C	- mm

2-5 Solenoid
Cut-in voltage max. 8 V
Test voltage: 12 - 14 V

D1

ZEXEL - Test values
Injection pumps



D2

ZEXEL - Test values
Injection pumps

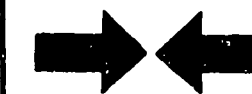

Test oil
ISO 4113 or
SAE J967d

ZEXEL - TEST VALUES
Distributor pumps
Engine model: 4D56

1/2

BOSCH No. 9 460 610 505
ZEXEL No. 104740-3763
Date: 30.09.1991 [0]
Company: MITSUBISHI
No. MD120184

Injection pump no.: 104640-3433

(NP-VE4/10F2000RNP515)

Pump rot.: Clockwise-viewed from drive side

Test-nozzle holder combination:
1 688 901 000

Test pressure line:
1 680 750 017

1. Setting values		Speed (rpm)	Setting values	Charge-air pressure bar (mmHg)	Difference in delivery (cc)
1-1	Timing device travel	1250	3.5 - 3.9 (mm)		
1-2	Supply pump pressure	1250	4.5 - 5.1 (kg/cm ²)		
1-3	Full load delivery	1250	45.3 - 46.3 (cc/1000st)		3.0
	Full load delivery		- (cc/1000st)		
1-4	Idle speed regulation	375	6.5 - 9.5 (cc/1000st)		2.0
1-5	Start	100	63.0 - 83.0 (cc/1000st)		
1-6	Full-load speed regulation	2150	15.1 - 21.1 (cc/1000st)		4.0
1-7	Load-timer adjustment	1250	T-0.4-0.8 (cc/1000st)		

2. Test values

2-1 Timing device	N = rpm	500	750	1250	2000
	mm	0.6-1.8	1.4-2.6	3.3-4.1	6.2-7.4
2-2 Supply pump	N = rpm	600		1250	2000
	kg/cm ²	2.9-3.5		4.5-5.1	6.3-6.9
2-3 Overflow delivery	N = rpm	1250			
	cc/10s	48.0-92.0			

2-4 Fuel injection quantities

Speed control lever pos.	Speed (rpm)	Fuel delivery (cc/1000st)	Charge-air pres (mmHg)	Difference in delivery (cc)
End stop	1250	44.8 - 46.8		
	600	42.3 - 46.3		
	2000	37.2 - 41.2		
	2150	13.1 - 23.1		
	2500	below 5.0		
Switch off	375	0		
Idle-stop	375	6.0 - 10.0		
	600	below 3.0		

2-5 Solenoid
Cut-in voltage max. 8 V
Test voltage: 12 - 14 V

3. Dimensions

K 3.2 - 3.4 mm
KF 5.7 - 5.9 mm
MS 1.1 - 1.3 mm
BCS - mm
Pre-str. - mm

Control lever angle

α 55° - 63° deg
A 10.9 - 16.0 mm
 β 40° - 50° deg
B 12.7 - 16.3 mm
 γ - deg
C - mm

D3

ZEXEL - Test values
Injection pumps



D4

ZEXEL - Test values
Injection pumps



1. Adjustment

1) Fix the control lever in the position satisfying the following conditions:

Boost Pressure: - mmHg
 Pump Speed : 1250 rpm
 Fuel Injection Quantity: 35.2 - 36.2 cc/1000st

2) With the control lever positioned as described in 1) above, adjust the governor sleeve so that the Timer Stroke conforms to the specified values (1 - 7).

2. Confirmation of Timer Characteristics

Fix the control lever in the position satisfying the following conditions, and confirm the Timer Stroke.

Control lever position			Specified values	
Pump speed (rpm)	Fuel injection quantity (cc/1000st)	Boost pressure (mmHg)	Timer stroke (mm)	Timer stroke reduction value (mm)
1250	34.7 - 36.7	-	(3.1)	0.2 - 1.0
1250	26.7 - 29.9	-	(2.3)	0.8 - 2.0

Test oil:
ISO 4113 or
SAE J967d

ZEXEL - TEST VALUES
Distributor pumps
Engine model: SD23

BOSCH No. 9 460 610 270
ZEXEL No. 104740-4261
Date: 30.09.1991 [0]
Company: NISSAN DIESEL
No. 16700 R8309

Injection pump no.: 104640-4261

(NP-VE4/10F2000RNP147)

Pump rot.: clockwise-viewed from drive side

Test-nozzle holder combination:
1 688 901 000

Test pressure line:
1 680 750 017

1. Setting values		P. Speed (rpm)	Setting values	Charge-air pressure bar (mmHg)	Difference (cc)
1-1	Timing device travel	1700	4.4 - 4.8 (mm)		
1-2	Supply pump pressure	1700	5.7 - 6.3 (kg/cm ²)		
1-3	Full load delivery	1000	35.6 - 36.6 (cc/1000st)		3.0
	Full load delivery		(cc/1000st)		
1-4	Idle speed regulation	300	4.3 - 8.3 (cc/1000st)		2.0
1-5	Start	100	55.0 - 90.0 (cc/1000st)		
1-6	Full-load speed regulation	2300	10.6 - 14.6 (cc/1000st)		
1-7	Load-timer adjustment				
1-8					

2. Test values

2-1 Timing device	N = rpm	1000	1700	2000
	mm	1.5 - 2.7	4.3 - 4.9	5.2 - 6.2
2-2 Supply pump	N = rpm	600	1700	2000
	kg/cm ²	3.2 - 3.8	5.7 - 6.3	6.5 - 7.1
2-3 Overflow delivery	N = rpm	1000		
	cc/10s	8.0 - 52.0		

2-4 Fuel injection quantities

Control lever position	Pump speed rpm	Fuel delivery (cc/1000 strokes)	Charge-air pres (mmHg)	Difference (cc)
End stop	1000	35.1 - 37.1		
	600	29.3 - 33.3		
	2000	30.5 - 34.7		
	2300	10.1 - 15.1		
	2450	below 5.0		
Switch off	300	0		
Idle stop	300	4.3 - 8.3		
	350	below 3.0		

2-5 Solenoid

Cut-in voltage max. 8 V
Test voltage: 12 - 14 V

3. Dimensions

K	3.2 - 3.4 mm
KF	5.7 - 5.9 mm
MS	1.4 - 1.6 mm
BCS	- mm
Pre-str.	- mm

Control lever angle

α	21° - 29° deg
A	4.0 - 9.2 mm
β	37° - 47° deg
B	10.7 - 14.8 mm
γ	- deg
C	- mm

D7

ZEXEL - Test values
Injection pumps



D8

ZEXEL - Test values
Injection pumps



Test oil
ISO 4113 or
SAE J967d

ZEXEL - TEST VALUES
Distributor pumps
Engine model: 4D56

1/2

BOSCH No.	9 460 610 508
ZEXEL No.	104740-8240
Date:	30.09.1991 [0]
Company:	MITSUBISHI
No.	MD171997

Injection pump no.: 104640-8240

(NP-VE4/10F2100RNP968)

Pump rot.: Clockwise-viewed from drive side

Test-nozzle holder combination:

Test pressure line:

1 688 901 000

1 680 750 017

1. Setting values		Speed (rpm)	Setting values	Charge-air pressure bar (mmHg)	Difference in delivery (cc)
1-1	Timing device travel	1250	3.5 - 3.9 (mm)		
1-2	Supply pump pressure	1250	4.5 - 5.1 (kg/cm ²)		
1-3	Full load delivery	1250	45.3 - 46.3 (cc/1000st)		3.0
	Full load delivery		- (cc/1000st)		
1-4	Idle speed regulation	375	6.5 - 9.5 (cc/1000st)		2.0
1-5	Start	100	63.0 - 83.0 (cc/1000st)		
1-6	Full-load speed regulation	2550	15.1 - 21.1 (cc/1000st)		4.0
1-7	Load-timer adjustment	1250	T-0.4-0.8 (cc/1000st)		

2. Test values

2-1 Timing device	N = rpm	500	750	1250	2100
	mm	0.6-1.8	1.4-2.6	3.3-4.1	6.6-7.8
2-2 Supply pump	N = rpm		600	1250	2100
	kg/cm ²		2.9-3.5	4.5-5.1	6.5-7.1
2-3 Overflow delivery	N = rpm			1250	
	cc/10s			48.0-92.0	

2-4 Fuel injection quantities

Speed control lever pos.	Speed (rpm)	Fuel delivery (cc/1000st)	Charge-air pres (mmHg)	Difference in delivery (cc)
End stop	1250	44.8 - 46.8		
	600	42.3 - 46.3		
	2100	37.2 - 41.2		
	2550	14.6 - 21.6		
	2900	below 5.0		
Switch off	375	0		
Idle-stop	600	below 3.0		
	375	6.0 - 10.0		

2-5 Solenoid
Cut-in voltage max. 8 V
Test voltage: 12 - 14 V

3. Dimensions

K	3.2 - 3.4 mm
KF	5.7 - 5.9 mm
MS	1.1 - 1.3 mm
BCS	- mm
Pre-str.	- mm

Control lever angle

α	19° - 27° deg
A	10.9 - 16.0 mm
β	36° - 46° deg
B	11.4 - 15.0 mm
γ	- deg
C	- mm

D9

ZEXEL - Test values
Injection pumps

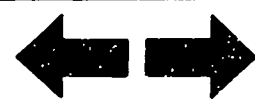

D10

ZEXEL - Test values
Injection pumps



1. Adjustment

1) Fix the control lever in the position satisfying the following conditions:

Boost Pressure: - mmHg
 Pump Speed : 1250 rpm
 Fuel Injection Quantity: 34.7 - 36.7 cc/1000st

2) With the control lever positioned as described in 1) above, adjust the governor sleeve so that the Timer Stroke conforms to the specified values (1 - 7).

2. Confirmation of Timer Characteristics

Fix the control lever in the position satisfying the following conditions, and confirm the Timer Stroke.

Control lever position			Specified values	
Pump speed (rpm)	Fuel injection quantity (cc/1000st)	Boost pressure (mmHg)	Timer stroke (mm)	Timer stroke reduction value (mm)
1250	34.7 - 36.7	-	3.1	0.2 - 1.0
1250	26.7 - 29.7	-	2.3	0.8 - 2.0

Test oil:
ISO 4113 or
SAE J967d

ZEXEL - TEST VALUES
Distributor pumps
Engine model: 4JA1AG

1/2

BOSCH No.	9 460 610 506
ZEXEL No.	104741-1112
Date:	30.09.1991 [0]
Company:	ISUZU
No.	8941403893

Injection pump no.: 104641-1062

(NP-VE4/11F1900LNP306)

Pump rotation: Counter clockwise-viewed
from drive side

Test-nozzle holder combination:
1 688 901 000

Test pressure line:
1 680 750 017

1. Setting values		P. Speed (rpm)	Setting values	Charge-air pressure bar (mmHg)	Difference (cc)
1-1	Time device travel	1500	2.1 - 2.5 (mm)		
1-2	Supply pump pressure	1500	5.0 - 5.4 (kg/cm ²)		
1-3	Full load delivery	1000	42.5 - 43.5 (cc/1000st)		3.5
	Full load delivery		(cc/1000st)		
1-4	Idle speed regulation	390	5.5 - 9.5 (cc/1000st)		2.0
1-5	Start	100	75.0 - 105.0 (cc/1000st)		
1-6	Full-load speed regulation	2100	13.1 - 19.1 (cc/1000st)		4.5
1-7	ACS adjustment	1000	Decrease 3.3 - 5.3 (cc/1000st)	-164 ± 5	

2. Test values

2-1 Timing device	Solenoid timer N = rpm mm	ON	OFF			
		500-700 0.5	1220-1320 0.5	1500 2.0-2.6	1800 4.1-5.1	1950 5.3-6.1
2-2 Supply pump	N = rpm kg/cm ²			1500 5.0-5.4		1900 5.1-6.7
2-3 Overflow delivery	N = rpm cc/10s			1500 67 - 110		

2-4 Fuel delivery quantities

Speed control lever pos.	Pump speed (rpm)	Fuel delivery (cc/1000st)	Charge-air pres (mmHg)	Difference (cc)
End stop	1000	42.0 - 44.0		
	1000	Decrease 2.8-5.8	-164±5	
	500	35.5 - 42.5		
	700	36.5 - 40.5		
	1350	42.2 - 46.2		
	1800	42.3 - 47.3		
	2100	12.6 - 19.6		
	2300	below 5.0		
Switch off	390	0		
Idle-stop	390	5.5 - 9.5		
	550	below 3.0		

2-5 Solenoid
Cut-in voltage max.: 8 V
Test voltage: 12 - 14 V

3. Dimensions

K	2.7 - 2.9 mm
KF	4.9 - 5.1 mm
MS	0.9 - 1.1 mm
BCS	- mm
Prestr.	1.31 - 1.35 mm
Control lever angle	
α	14° - 22° deg
A	2.5 - 7.6 mm
β	32° - 42° deg
B	9.3 - 13.2 mm
γ	- deg
C	- mm

D13

ZEXEL - Test values
Injection pumps



D14

ZEXEL - Test values
Injection pumps



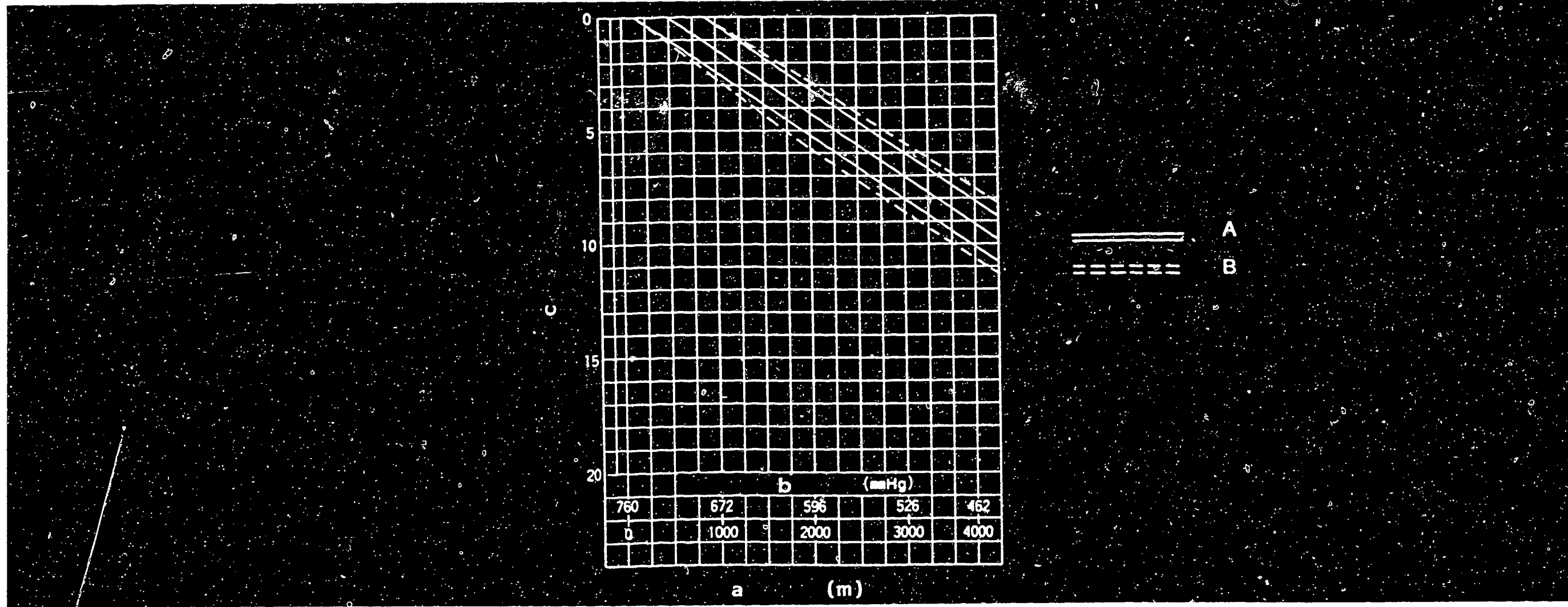

Figure 18
 a = Altitude
 b = Atmospheric pressure
 c = Injection quantity decrease (cc/1000st)

A = Adjustment limit
 B = Inspection limit

■ FULL-LOAD FUEL INJECTION QUANTITY AND ACS ADJUSTING PROCEDURE AT HIGH ALTITUDES

1. FULL-LOAD FUEL INJECTION QUANTITY ADJUSTMENT

- 1) Remove the ACS cover, the bellows and the adjusting shims.
- 2) Perform all adjustments as described in the adjusting specifications, except for ACS adjustment.

2. ACS ADJUSTMENT

- 1) Attach the ACS cover, the bellows and the adjusting shims.
- 2) At a pump speed of 1000 rpm and referring to the graph above, use the shims to adjust the fuel injection quantity decrease according to the altitude.

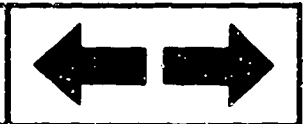

Test oil:
ISO 4113 or
SAE J967d

ZEXEL - TEST VALUES
Distributor pumps
Engine model: 4FB1

BOSCH No. 9 460 610 477
ZEXEL No. 104748-1670
Date: 30.09.1991 [0]
Company: ISUZU
No. 3-94241-NHK-A

Injection pump no.: 104648-1330

(NP-VE4/8F900RNP393)

Pump rot.: clockwise-viewed from drive side

Test-nozzle holder combination:
1 688 901 000

Test pressure line:
1 680 750 017

1. Setting values		P. Speed (rpm)	Setting values	Charge-air pressure bar (mmHg)	Difference (cc)
1-1	Timing device travel		(mm)		
1-2	Supply pump pressure	800	3.5 - 3.9 (kg/cm ²)		
1-3	Full load delivery	800	31.1 - 32.1 (cc/1000st)		2.5
	Full load delivery		(cc/1000st)		
1-4	Idle speed regulation	300	6.0 - 10.0 (cc/1000st)		2.0
1-5	Start	100	above 40.0 (cc/1000st)		
1-6	Full-load speed regulation	900	25.7 - 29.7 (cc/1000st)		3.5
1-7					
1-8					

2. Test values

2-1 Timing device	N = rpm mm		
2-2 Supply pump	N = rpm kg/cm ²	400 2.2 - 2.8	800 3.5 - 3.9
2-3 Overflow delivery	N = rpm cc/10s		800 37.0 - 80.0

2-4 Fuel injection quantities

Control lever position	Pump speed rpm	Fuel delivery (cc/1000 strokes)	Charge-air pres (mmHg)	Difference (cc)
End stop	800	30.6 - 32.6		
	900	25.2 - 30.2		
	935	9.3 - 18.3		
Switch off	300	0		
Idle stop	250	36.3 - 42.3		
	300	6.0 - 10.0		
	350	below 3.0		

2-5 Solenoid
Cut-in voltage max. 8 V
Test voltage: 12 - 14 V

3. Dimensions

K	3.2 - 3.4 mm
KF	5.7 - 5.9 mm
MS	1.7 - 1.9 mm
BCS	- mm
Pre-str.	- mm

Control lever angle

α	-6° - 2° deg
A	7.5 - 22.8 mm
β	35° - 45° deg
B	11.2 - 14.4 mm
γ	- deg
C	- mm

D17

ZEXEL - Test values
Injection pumps



D18

ZEXEL - Test values
Injection pumps

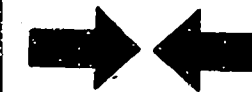

Test oil:
ISO 4113 or
SAE J967d

ZEXEL - TEST VALUES
Distributor pumps
Engine model: S2

BOSCH No. 9 460 610 503
ZEXEL No. 104749-0020
Date: 30.09.1991 [0]
Company: MAZDA
No. 826413800

Injection pump no.: 104649-0020

(NP-VE4/9F2125LNP28)

Pump rot.: Counter clockwise-viewed from
drive side

Test-nozzle holder combination:
1 688 901 000

Test pressure line:
1 680 750 017

1. Setting values		P. Speed (rpm)	Setting values	Charge-air pressure bar (mmHg)	Difference (cc)
1-1	Timing device travel	1250	1.3 - 1.7 (mm)		
1-2	Supply pump pressure	1250	3.8 - 4.4 (kg/cm ²)		
1-3	Full load delivery	1500	39.2 - 40.2 (cc/1000st)		3.0
	Full load delivery		(cc/1000st)		
1-4	Idle speed regulation	325	5.2 - 9.2 (cc/1000st)		2.5
	Start	100	above 60.0 (cc/1000st)		
1-6	Full-load speed regulation	2400	8.0 - 12.0 (cc/1000st)		
1-7					
1-8					

2. Test values

2-1 Timing device	N = rpm mm	1250 1.2 - 1.8	1500 2.8 - 4.0	2125 8.3 - 9.2
2-2 Supply pump	N = rpm kg/cm ²	500 1.3 - 1.9	1250 3.8 - 4.4	2125 6.8 - 7.4
2-3 Overflow delivery	N = rpm cc/10s	1250 53.0 - 97.0		
2-4 Fuel injection quantities				
Control lever position	Pump speed rpm	Fuel delivery (cc/1000 strokes)	Charge-air pres (mmHg)	Difference (cc)
End stop	1500	38.7 - 40.7		
	500	30.4 - 34.4		
	2125	33.0 - 37.0		
	2400	7.0 - 13.0		
	2500	below 6.0		
Switch off	325	0		
Idle stop	325	5.2 - 9.2		
	below 450	0		
2-5 Solenoid	Cut-in voltage max. 8 V Test voltage: 12 - 14 V			

3. Dimensions

K	3.2 - 3.4 mm
KF	5.7 - 5.9 mm
MS	1.7 - 1.9 mm
BCS	- mm
Pre-str.	- mm
Control lever angle	
α	34° - 42° deg
A	- mm
β	45° - 55° deg
B	- mm
γ	- deg
C	- mm

D19

ZEXEL - Test values
Injection pumps

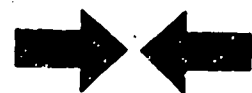

D20

ZEXEL - Test values
Injection pumps



Test oil:
ISO 4113 or
SAE J967d

ZEXEL - TEST VALUES
Distributors pumps
Engine model: LD20 (VC)

1/4

BOSCH No.	9 460 610 358
ZEXEL No.	104749-2310
Date:	30.09.1991 [0]
Company:	NISSAN
No.	16700 14CE1

Injection pump no: 104649-2240

(NP-VE4/9F2300RNP454)

Pump rot.: Clockwise-viewed from drive side

Test-nozzle holder combination:
1 688 901 000

Test pressure line:
1 680 750 017

1. Setting values		P. speed (rpm)	Setting values	Charge-air pressure bar (mmHg)	Difference (cc)
1-1	Timing device travel	900	T=1.3 - 1.7 (mm)		2.5
1-2	Supply pump pressure	900	3.2 - 3.8 (kg/cm ²)		
1-3	Full load delivery	900	32.5 - 33.5 (cc/1000st)		
	Full load delivery		(cc/1000st)		
1-4	Idle speed regulation	350	4.7 - 7.7 (cc/1000st)		
1-5	Start	100	40.0 - 50.0 (cc/1000st)		
1-6	Full-load speed regulation	2500	10.6 - 16.6 (cc/1000st)		
1-7	Load-timer adjustment	900	T=0.63-0.67 (mm)		
1-8					

2. Test values

2-1 Timing device	N = rpm	900	1800	2300
	mm	1.2 - 1.8	5.5 - 6.7	7.7 - 8.9
2-2 Supply pump	N = rpm	900	1800	2300
	kg/cm ²	3.1 - 3.9	5.1 - 5.9	6.2 - 7.0
2-3 Overflow delivery	N = rpm	900		
	cc/10s	35.0 - 79.0		

2-4 Fuel injection quantities

Control lever position	Pump speed (rpm)	Fuel delivery (cc/1000 strokes)	Charge-air pres (mmHg)	Difference (cc)
End stop	900	32.0 - 34.0		
	600	31.2 - 35.2		
	2300	29.3 - 33.3		
	2500	10.1 - 17.1		
	2600	below 6.0		
Switch off	350	0		
Idle stop	350	4.2 - 8.2		2.5
	500	below 3.0		
Partial load	900	4.1 - 14.1		
2-5 Solenoid	Cut-in voltage max. 8 V Test voltage: 12 - 14 V			

3. Dimensions

K	3.2 - 3.4 mm
KF	5.7 - 5.9 mm
MS	1.1 - 1.3 mm
BCS	- mm
Pre-st.	- mm
Control lever angle	
α	21° - 29° deg
A	4.3 - 9.6 mm
β	36° - 46° deg
B	10.9 - 14.6 mm
γ	10.5 - 11.5 deg
C	6.9 - 7.5 mm

D21

ZEXEL - Test values
Injection pumps



D22

ZEXEL - Test values
Injection pumps



1. Adjustment

1) Fix the control lever in the position satisfying the following conditions:

Boost Pressure:	-	mmHg
Pump Speed :	900	rpm
Fuel Injection Quantity:	17 ± 1	cc/1000st

2) With the control lever positioned as described in 1) above, adjust the governor sleeve so that the Timer Stroke conforms to the specified values.

STARTING INJECTION QUANTITY ADJUSTMENT

Adjust the starting injection quantity using the adjusting bolt (as shown in the figure at right).

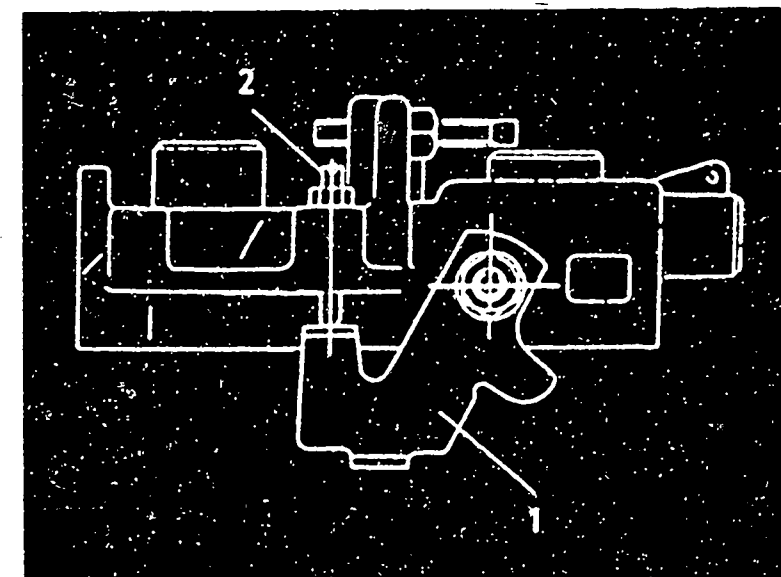

Figure 19

- 1 = Adjusting bolt
- 2 = Stop lever



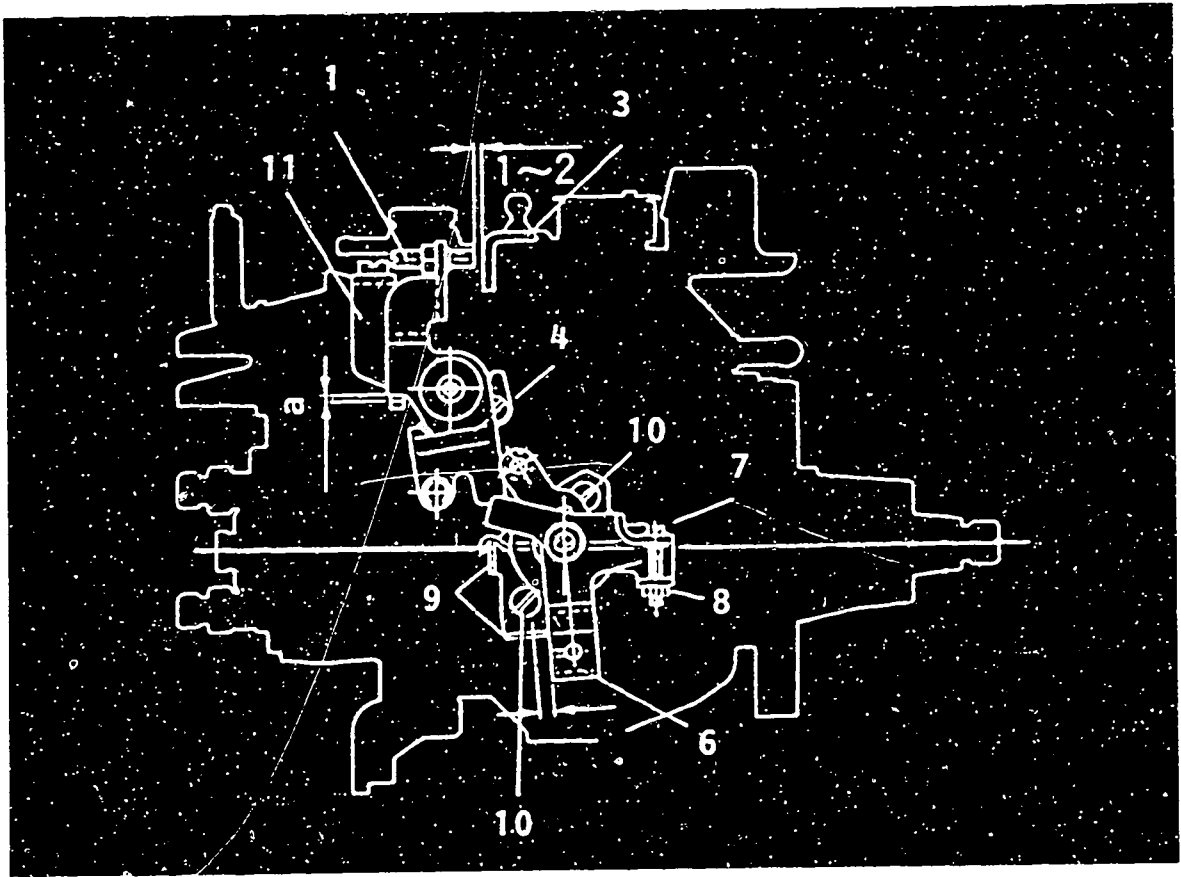

Figure 20

104749-2310 3/4

- 1 = Adjusting screw
- 3 = Control lever
- 4 = Intermediate lever
- 6 = CSD lever
- 7 = Screw

- 8 = Nut
- 9 = Stopper
- 10 = Screw
- 11 = Intermediate lever bracket
- a = Block gauge

■ M-CSD ADJUSTMENT

1. Fix the intermediate lever adjustment screw in position. (Adjust with the M-CSD released)

- 1) Hold the control lever (3) in the idling position.
- 2) Move the adjusting screw to a horizontal position.

3) Adjust using the adjusting screw (1) so that the gap between the control lever (3) and the adjusting screw (1) is 1 - 2 mm, and then fix using the nut.



2. Fixing the M-CSD Stopper (9)

- 1) Turn the drive shaft slowly, and fix the drive shaft in a position where a load is applied (the point where the roller in the roller holder contacts the cam surface of the cam disc).
- 2) Move the CSD lever (6) to the advance side.
- 3) Fix the CSD lever in the position where the ball pin at the tip of the shaft lightly contacts the roller holder (roller holder advance angle "0").
- 4) Move the CSD lever to the advance side.
- 5) Then, adjust the position of the stopper (9) so that the timer stroke is 1.23 ± 0.2 mm, and fix the stopper (9) using the screw (10).

3. Screw (7) Adjustment

- 1) Fix the control lever in the idling position.
- 2) Move the CSD lever to the advance side.
- 3) Then, adjust the screw (7) so that the clearance between the control lever and the idling stopper bolt is 7.2 ± 0.5 mm, and fix the screw (7) using the nut (8).



Test oil
ISO 4113 or
SAE J967d

ZEXEL - TEST VALUES
Distributor pumps
Engine model: 4FC1EC

BOSCH No. 9 460 610 498
ZEXEL No. 104749-6551
Date: 30.09.1991 [0]
Company: ISUZU
No. 8944349530

Injection pump no.: 104649-1941

(NP-VE4/9F2250RNP49)

Pump rot.: Clockwise-viewed from drive side

Test-nozzle holder combination:
1 688 901 000

Test pressure line:
1 680 750 017

1. Setting values	P. Speed (rpm)	Setting values	Charge-air pressure bar (mmHg)	Difference in delivery (cc)
1-1 Timing device travel	1250	2.9 - 3.3 (mm)		
1-2 Supply pump pressure	1250	4.6 - 5.0 (kg/cm ²)		
1-3 Full load delivery	1250	33.7 - 34.7 (cc/1000st)		2.5
1-4 Idle speed regulation	315	5.6 - 9.6 (cc/1000st)		2.1
1-5 Start	100	50.0 - 70.0 (cc/1000st)		
1-6 Full-load speed regulation	2600	14.5 - 16.5 (cc/1000st)		4.5
1-7				

2. Test values

2-1 Timing device	N = rpm mm	640 - 840 0.5	1250 2.8-3.4	1800 5.3-6.5	2250 7.8-8.6
2-2 Supply pump	N = rpm kg/cm ²	1250 4.6-5.0	2000 6.2-6.8		
2-3 Overflow delivery	N = rpm cc/10s	1250 55.0-98.0			
2-4 Fuel injection quantities					
Speed control lever pos.	Pump Speed (rpm)	Fuel delivery (cc/1000st)	Charge-air pres (mmHg)	Difference in delivery (cc)	
End stop	1250	33.2 - 35.2			
	600	26.2 - 30.2			
	1800	31.7 - 35.7			
	2250	30.6 - 34.8			
	2600	14.0 - 17.0			
	2900	below 4.0			
Switch off	315	0			
Idle-stop	315	5.6 - 9.6			
	450	0			
2-5 Solenoid	Cut-in voltage max. 8 V Test voltage: 12 - 14 V				

3. Dimensions

K	3.2 - 3.4 mm
KF	5.7 - 5.9 mm
MS	1.5 - 1.7 mm
BCS	- mm
Pre-str.	0.23 - 0.27 mm
Control lever angle	
α	-6° - 2° deg
A	8.5 - 11.1 mm
β	33° - 43° deg
B	10.5 - 13.8 mm
γ	- deg
C	- mm

D27

ZEXEL - Test values
Injection pumps



D28

ZEXEL - Test values
Injection pumps



Test Oil
ISO 4113 or
SAE J967d

ZEXEL - TEST VALUES
Distributor pumps
Engine model: TD42T
(NP-VE6/10F1750RNP70)

BOSCH No. 9 460 610 510 1/3
ZEXEL No. 104760-4121
Date: 30.09.1991 [0]
Company: NISSAN DIESEL
No. 16700 05D00

Injection pump no.: 104660-4121

Pump rot.: Clockwise-viewed from drive side

Test-nozzle holder combination:
1 688 901 022

Test pressure line:
1 680 750 073

1. Setting values		P. speed (rpm)	Setting values	Charge air pressure bar (mmHg)	Difference in delivery (cc)
1-1	Timing device travel	1000	S/T ON 3.3 - 4.1 (mm) *) OFF 1.1 - 1.5 (mm)	*) S/T = Solenoid Timer	3.5
1-2	Supply pump pressure	1500	4.3 - 4.9 (kg.cm ²)		
1-3	Full load delivery	1000	54.5 - 55.5 (cc/1000st)		
	Full load delivery		(cc/1000st)		
1-4	Idle speed regulation	350	7.1 - 11.1 (cc/1000st)		
1-5	Start	100	50.0 - 80.0 (cc/1000st)		
1-6	Full-load speed regulation	1900	52.3 - 56.3 (cc/1000st)		
1-7	Load-timer adjustment	1000	T-1.0 - 1.4 (mm)		
1-8	A.C.S adjustment	1000	46.3 - 49.3 (cc/1000st)	-164±5	

2. Test values

2-1 Timing device	Sol.Timer N = rpm mm	ON		OFF			
		1000	800	1000	1500	1750	2000
		3.2-4.2	0.0-1.0	1.0-1.6	3.0-4.2	3.7-5.1	5.1-6.1
2-2 Supply pump	N = rpm kg/cm ²			1000	1500	1750	
				2.9-3.5	4.3-4.9	4.8-5.4	
2-3 Overflow delivery	N = rpm cc/10s	1500 (S/T ON) 78 - 122		1500 (S/T ON;less 68-112 O-Ring)			

2-4 Fuel injection quantities

Speed control lever pos.	Pump speed (rpm)	Fuel delivery (cc/1000st)	Charge-air pres (mmHg)	Difference in delivery (cc)
End stop	1000	54.0 - 56.0	-164±5	
	400	43.9 - 53.9		
	600	45.7 - 52.7		
	1000	45.8 - 49.8		
	1750	60.0 - 67.0		
	1900	51.8 - 56.8		
	2100	12.2 - 22.2		
	2300	below 5.0		
Switch off	350	0		
	100	0		
Idle-stop	450	below 3.0		
	350	7.1 - 11.1		

2-5 Solenoid

Cut-in voltage max. 8 V
Test voltage: 12 - 14 V

3. Dimensions

K	3.2 - 3.4 mm
KF	5.7 - 5.9 mm
MS	0.9 - 1.1 mm
BCS	- mm

Control Lever Angle

α	6° - 14° Angle
A	9.6 - 13.8 mm
β	29° - 39° Angle
B	8.7 - 12.3 mm
γ	- Angle
C	- mm

E1

ZEXEL - Test values
Injection pumps



E2

ZEXEL - Test values
Injection pumps



1. Adjustment

1) Fix the control lever in the position satisfying the following conditions:

Boost Pressure: mmHg
 Pump Speed : 1000 rpm
 Fuel Injection Quantity: 33.5 - 34.5 cc/1000st

2) With the control lever positioned as described in 1) above, adjust the governor sleeve so that the Timer Stroke conforms to the specified values (1 - 7).

2. Confirmation of Timer Characteristics

Fix the control lever in the position satisfying the following conditions, and confirm the Timer Stroke.

Control lever position			Specified values	
Pump speed (rpm)	Fuel injection quantity (cc/1000st)	Boost pressure (mmHg)	Timer stroke (mm)	Timer stroke reduction value (mm)
1000	33.0 - 35.0	-	-	0.9 - 1.5
1000	23.5 - 26.5	-	-	0.9 - 1.9

Note:

- Adjust the pump chamber pressure, timing device stroke, fuel injection quantity, and the solenoid timer with the switch OFF.
- Before temporarily adjusting full-load quantity, temporarily adjust the pump chamber pressure (Pt) to 3 - 4 kg/cm² at Np = 1500 rpm.
- Load Timer Adjustment
 Because the timer stroke (Δ TA) is small, adjust TA to 2.5 ± 0.2 mm at a fuel injection quantity of 34 ± 0.5 after adjusting the timer. Then, confirm that TA = 1.3 ± 0.2 mm at a fuel injection quantity of 50 ± 1.0 .

E3 ZEXEL - Test values
 Injection pumps 

E4 ZEXEL - Test values
 Injection pumps 

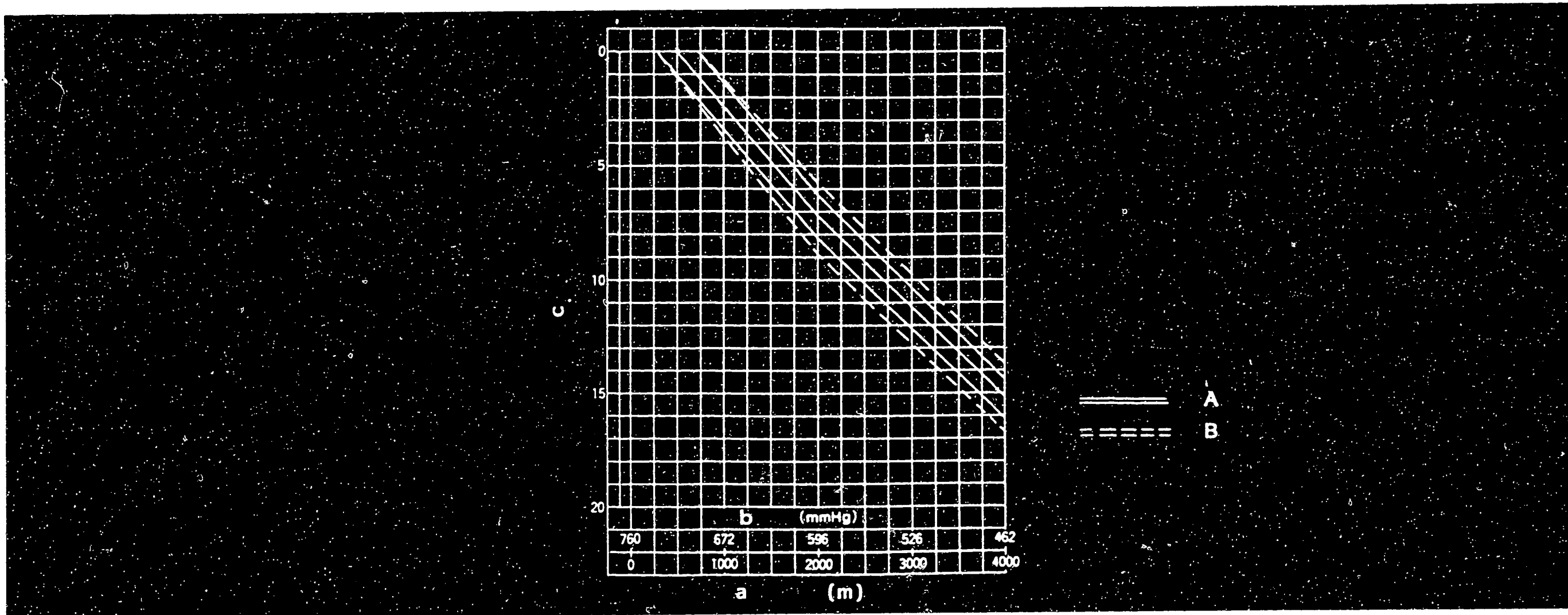

Figure 21
 a = Altitude
 b = Atmospheric pressure
 c = Injection quantity decrease (cc/1000st)

A = Adjustment limit
 B = Inspection limit

■ FULL-LOAD FUEL INJECTION QUANTITY AND ACS ADJUSTING PROCEDURE AT HIGH ALTITUDES

1. FULL-LOAD FUEL INJECTION QUANTITY ADJUSTMENT

- 1) Remove the ACS cover, the bellows and the adjusting shims.
- 2) Perform all adjustments as described in the adjusting specifications, except for ACS adjustment.